

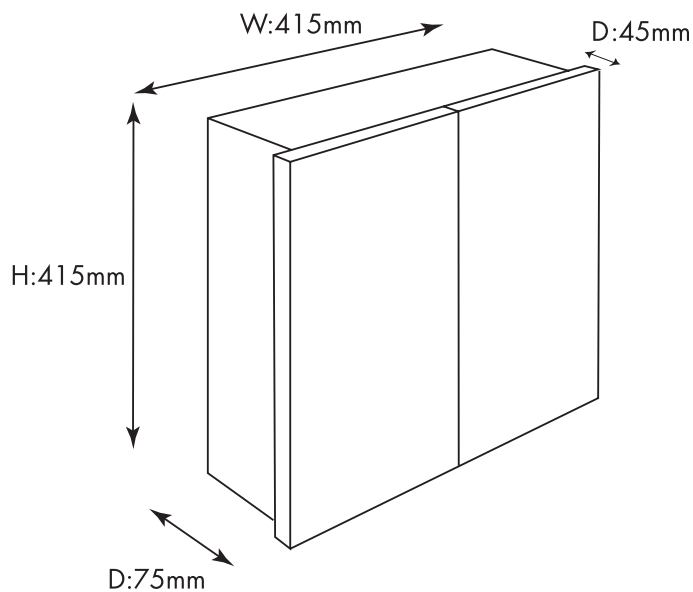

Duonet Repeater panel



#### Technical Specification

Compatibility:	Quadnet control panels
Construction:	Mild Steel
Operating Temperature:	5°C to 33°C
Voltage Range:	16 to 48 V DC
Mains Voltage:	230V AC +10% -15%
Panel Inputs/Outputs:	2 x network port 1 x USB port for site config upgrade 1 x serial port for panel software upgrade
Current Consumption:	Quiescent: 98mA Alarm: 250mA
Battery Requirements:	2 x 12v 7.2Ah
Part Code:	510 0002