

# Bandit Security Sounder

This compact, low cost 108dBA Security Sounder is designed as a stand alone unit for internal use. The unit is also capable of operating in an external protected environment such as polycarbonate bell boxes. The unit is surface mounted and is able to utilise square trunking.

Exclusively distributed by VimpeX, the Bandit Security Sounder combines acoustic knowledge together with a high standard of styling and design synonymous with Hosiden Besson.



## Features

- Supply voltage 12 Vdc
- High output - 108dBA typical
- Low current - 70mA typical
- Anti-tamper switch fitted as standard on 12V model
- Distinct sound - yodel 2 times per second
- Surface mounting - utilises BS4662 and 5733 wall boxes



## Specification

Model (Part No.)	Standard (8480100)
Rated Voltage $\pm 25\%$	12 Vdc
Rated Current (typical)	70 mA
Sound Output (typical) dBA @ 1M	108
Tone Frequency	Yodel: 1.9kHz - 2.7kHz (250mS each frequency)
Weatherproofing	IP45 as standard
Colour	White
Anti-tamper	Miniature microswitch with 'held closed' contacts on 12V version
Connections: 6V	2 way terminal block 2.5mm <sup>2</sup> dia
12V	4 way terminal block 2.5mm <sup>2</sup> dia
24V	2 way terminal block 2.5mm <sup>2</sup> dia CSA wire (max)

## Installation

### Bandit Sounder

Dimensions (mm)

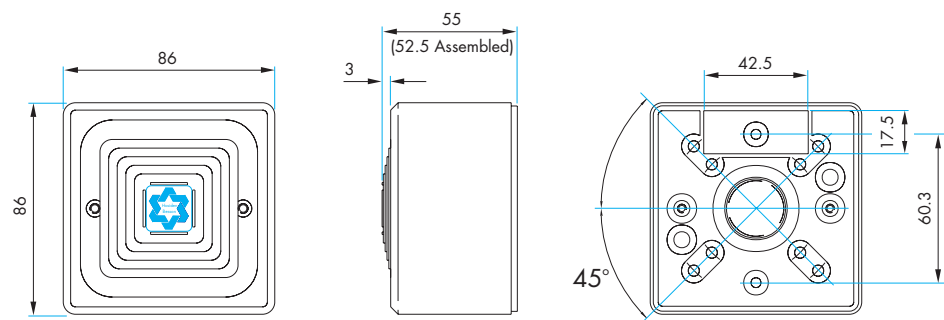

# VIMPEX

### Vimpex Ltd

Star Lane, Great Wakering  
Essex, SS3 0PJ England.  
Tel: +44 (0) 1702 216999  
Fax: +44 (0) 1702 216699  
E-mail: sales@vimpex.co.uk

[www.vimpex.co.uk](http://www.vimpex.co.uk)



We reserve the right to change or amend any design or specification in line with our policy of continuing development and improvement.

Part No: DS/BAND/ISS 3

## Other Products and Accessories



- Fire-Cryer® Voice Enhanced Sounders
- Electronic Sounders
- Fire Alarm Bells
- Beacons and Strobe Lights
- Sounder Accessories & Fire System Ancillaries
- Stopper Range of Vandal Deterrent Products
- Water Leakage Detection Systems