

TAKEX PHOTOELECTRIC BEAM SENSOR

PB- 30TK (K) : Outdoor 100ft. (30m) / Indoor 200ft. (60m)
 PB- 60TK (K) : Outdoor 200ft. (60m) / Indoor 400ft. (120m)
 PB-100TK (K) : Outdoor 330ft. (100m) / Indoor 660ft. (200m)

Instruction Manual

We appreciate your purchase of our photoelectric beam sensor. This sensor will provide long and dependable service when properly installed. Please read this Instruction Manual carefully for correct and effective use.

Please Note: This sensor is designed to detect intrusion and to initiate an alarm ; it is not a burglary-preventing device.

We are not responsible for damage, injury or losses caused by accident, theft, Acts of God (including inductive surge by lightning), abuse, misuse, abnormal usage, faulty installation or improper maintenance.

Remarks : PB- 30TK (K) is same as PB- 30TK
 PB- 60TK (K) is same as PB- 60TK
 PB-100TK (K) is same as PB-100TK

1 PARTS DESCRIPTION

[TRANSMITTER]

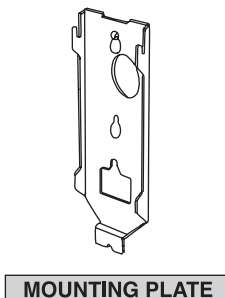
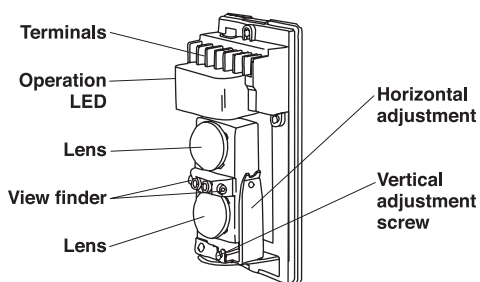

[OPTION PARTS]

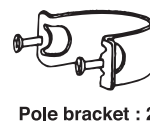
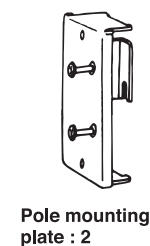

[RECEIVER]

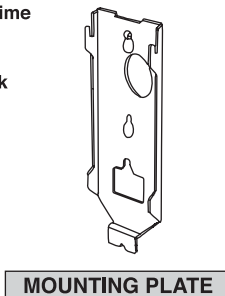
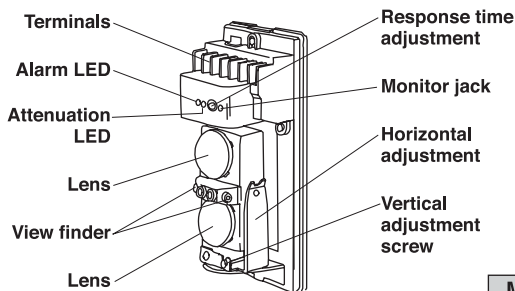

2 CAUTIONS ON INSTALLATION

DO'S AND DON'T'S



- Remove all obstructions (trees, clothes lines, etc.) between Transmitter and Receiver.



- Avoid strong light from the sun, automobile headlights etc. directly shining on Transmitter / Receiver. When strong light stays in optical axis for a long time, it does not cause malfunction but will affect the product life.



- Do not install the unit on places where it may be splashed by dirty water or direct sea spray.



- Do not install the unit on unsteady surfaces.

- The protection distance (between Transmitter / Receiver) should be placed in the rated range.

PB- 30TK : Outdoor : 100' (30m) / Indoor : 200' (60m)
 PB- 60TK : Outdoor : 200' (60m) / Indoor : 400' (120m)
 PB-100TK : Outdoor : 330' (100m) / Indoor : 660' (200m)

Expansion of beam

Expansion of beam can be calculated as follows.

$$A=0.03 \times \ell$$

ℓ	A
66' (20m)	2' (0.6m)
135' (40m)	4' (1.2m)
200' (60m)	6' (1.8m)
330' (100m)	10' (3.0m)

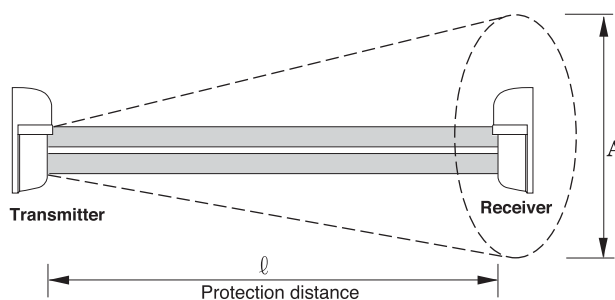

POINTS OF INSTALLATION

Heights of installation

Install the sensor at a height of 31" to 39" (80 to 100cm) to catch human pattern.

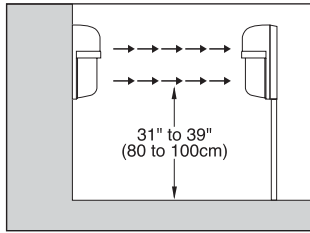

Position of installation

Using the adjustments, the lens can move horizontally (± 90 degrees) and vertically (± 10 degrees) allowing the unit to work in all directions. (example 1 to 3)

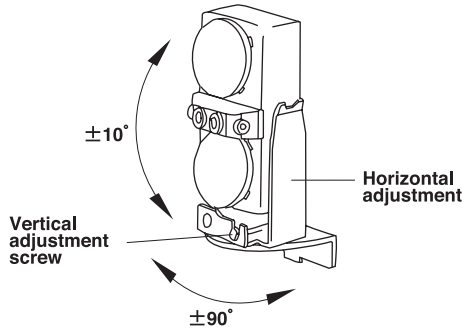

Example 1

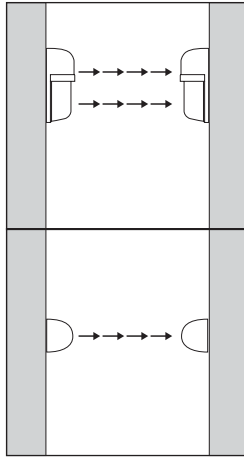

Example 2

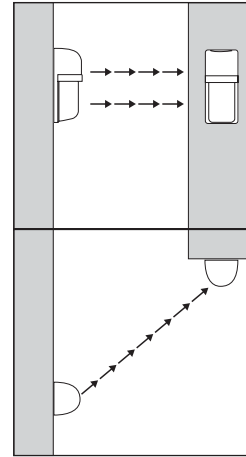

Example 3

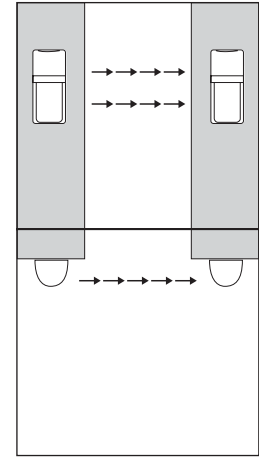

CAUTIONS ON INSTALLATION

- Avoid overhead wiring.
- When installing indoors, wiring procedures similar to those for telephones or intercoms are acceptable. Outdoor wires should be placed inside pipes, or underground cable / metal shielded cable should be used.

3 WIRING

Terminal configuration

[Transmitter]

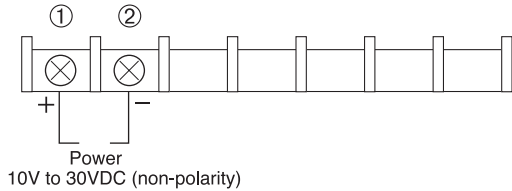

[Receiver]

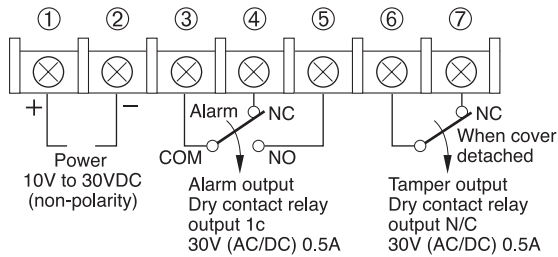

●Wiring distance

model wire size	voltage	PB-30TK		PB-60TK, PB-100TK	
		12V	24V	12V	24V
AWG22 (Dia 0.65mm)		720' (220m)	6200' (1890m)	490' (150m)	4200' (1280m)
AWG20 (Dia 0.8mm)		1200' (366m)	10500' (3200m)	830' (250m)	7200' (2200m)
AWG18 (Dia 1.0mm)		1800' (549m)	16000' (4880m)	1200' (366m)	10500' (3200m)
AWG17 (Dia 1.1mm)		2200' (670m)	20000' (6000m)	1450' (442m)	13500' (4000m)

- Note 1) Maximum wiring distance when two or more sets are connected is the value above divided by the number of sets.
 2) The signal line can be wired to a distance of up to 3,300 ft. (1,000m) with AWG22 (dia 0.65mm) telephone wire.

Connection

●Example connection 1

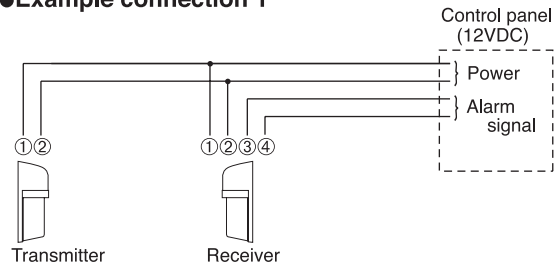

●Example connection 2

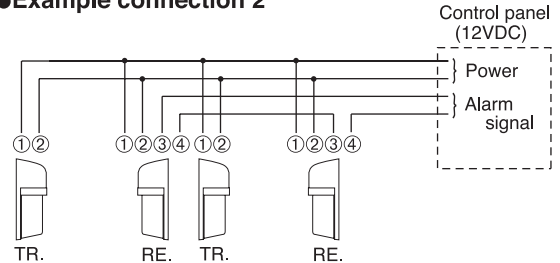

●Example connection 3

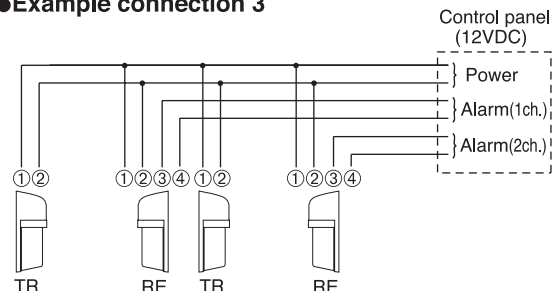

4 INSTALLATION

Wall Mount

1) Remove cover from unit and slide the mounting plate to detach it.

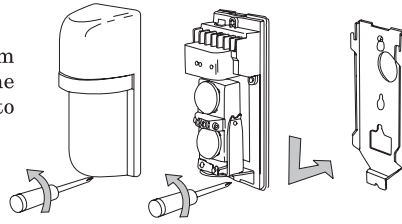

2) Pull wire through on the installation site.

3) Break grommet on mounting plate and pull wire through it. Secure the plate with 4mm screws.

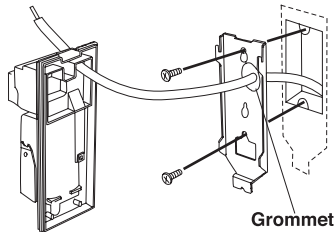

Pull wire through sensor body (back to front) and attach it to the mounting plate.

4) When exposed wired, break knockouts (2 positions) on the rear of unit, pull wire through as the figure and attach it to the mounting plate.

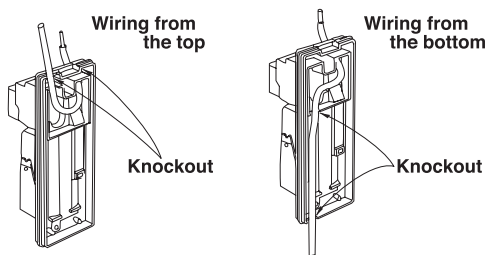

5) After wiring is completed, adjust alignment, check operation and attach cover.

(Note : Sealing is not required for unit surround due to rain-proof construction.)

※ The grommet is compatible with a wire of $\phi 0.12"$ ($\phi 3\text{mm}$) to $\phi 0.24"$ ($\phi 6\text{mm}$) outer dia.

When a wire of more than $\phi 0.24"$ ($\phi 6\text{mm}$) outer dia. is used, cut off the dotted line portion on the below figure by pliers or the like.

Then make corking to prevent insects from entering into the unit.

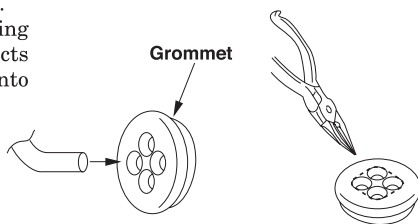

5 ALIGNMENT AND OPERATION

● Supply power with cover detached.

● Set Transmitter lens to Receiver lens.

The view finder is placed between 2 lenses.

Look through view finder on either side and line-up optics horizontally and vertically until the opposite unit is visible. (Hold the mental portion and change horizontal angle.)

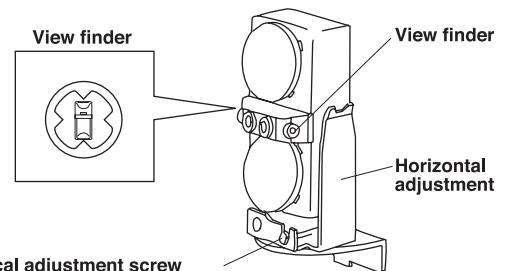

Vertical adjustment screw
Clockwise : Upward
Counterclockwise : Downward

● Further, fine tune until receiver attenuation LED is OFF.

● When the unit is used outdoors, a tester is advisable to be used for adjustment. You can confirm the beam level by inserting a tester in monitor jack of Receiver.

The reference follows.

Monitor output voltage	Alignment (outdoor)	Alignment (indoor)
700mV or more	Best	Best
250mV to 700mV	Good	
60mV to 250mV	Re-adjustment	Good
less than 60mV		Re-adjustment

Note : The above voltage shows attenuation sheet condition.

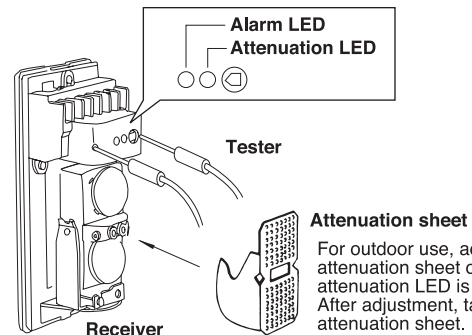

[Testing] Units should be tested on a regular monthly basis. To test, walk in front of Receiver and watch to see if the walk test LED lights as the beam is blocked. Relay function should be confirmed by watching status light on control panel.

[Maintenance] Our photoelectric beam are virtually maintenance free, with the exception of units that are located in dusty or dirty environments. Dirty units should be cleaned off with a damp cloth as necessary.

6 RESPONSE TIME

Adjust response time as follows. The unit does not detect the passing object faster than the response time set. If the response time is set longer, the unit does not detect human beings. Adjust to a little longer response time in a site where large passing objects, such as birds, newspaper or carton box may move.

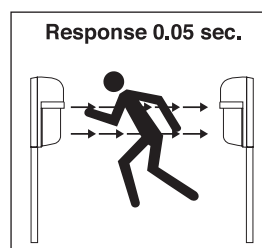
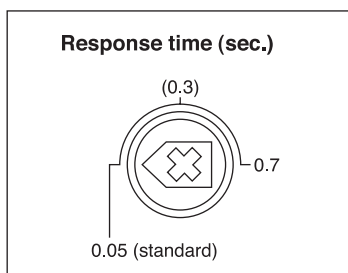

Run at full speed

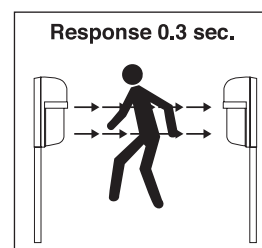

Walk with quick steps.

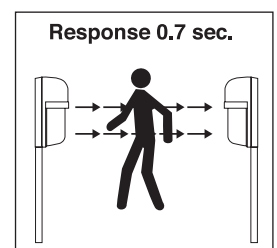

Walking

7 TROUBLESHOOTING

Symptom	Possible Cause	Remedy
Operation LED does not light.	1) No power supply. 2) Bad wiring connection or broken wire, short.	1) Turn on the power. 2) Check wiring.
Alarm LED does not light when the beam is broken.	1) No power supply. 2) Bad wiring connection or broken wire, short. 3) Beam is reflected on another object and sent into the receiver. 4) Two beams are not broken simultaneously. 5) The beam interruption time is shorter than the set response time.	1) Turn on the power supply. 2) Check wiring. 3) Remove the reflecting object or change beam direction. 4) Break two beams simultaneously. 5) Set the response time shorter.
Alarm LED continues to light.	1) Beam alignment is out. 2) Shading object between Transmitter and Receiver. 3) Optics of units are soiled.	1) Check and adjust again. 2) Remove the shading object. 3) Clean the optics with a soft cloth.
Intermittent alarms.	1) Bad wiring connection. 2) Change of supply voltage. 3) Shading object between Transmitter and Receiver. 4) A large electric noise source, such as power machine, is located nearby Transmitter and Receiver. 5) Unstable installation of Transmitter and Receiver. 6) Soiled optics of Transmitter and Receiver. 7) Improper alignment. 8) Small animals may pass through the 2 beams.	1) Check again. 2) Stabilize supply voltage. 3) Remove the shading object. 4) Change the place for installation. 5) Stabilize. 6) Clean the optics with a soft cloth. 7) Check and adjust again. 8) Set the response time longer. (Impossible in a site where an intruder can run at full speed.)

8 SPECIFICATIONS

Model	PB-30TK	PB-60TK	PB-100TK
Detection system	Simultaneous breaking of 2 beams		
Infrared beam	LED pulsed beam, Double modulation		
Protection distance	Outdoor 100' (30m) or less Indoor 200' (60m) or less	Outdoor 200' (60m) or less Indoor 400' (120m) or less	Outdoor 330' (100m) or less Indoor 660' (200m) or less
Max. beam range (Approximation)	Outdoor 1000' (300m) Indoor 1000' (300m)	Outdoor 2000' (600m) Indoor 2000' (600m)	Outdoor 3300' (1000m) Indoor 3300' (1000m)
Response time	50msec. to 700msec. (Variable at pot)		
Supply voltage	10V to 30VDC (Non-polarity)		
Current consumption	53mA or less	80mA or less	
Alarm output	Dry contact relay output form C Contact action : Interruption time + delay time (1 to 3 sec.) Contact capacity : 30V AC/DC, 0.5A or less		
Tamper output	Dry contact relay N/C Action : Activated when cover is detached. Contact capacity : 30V AC/DC, 0.5A or less		
Alarm LED	Red LED (Receiver) ON : when an alarm is initiated.		
Attenuation LED	Red LED (Receiver) ON : when beam is attenuated.		
Functions	Monitor jack output, AGC circuit, Frost proof cover		
Ambient temperature range	-13° F to +140° F (-25° C to +60° C)		
Mounting positions	Indoor / Outdoor		
Wiring	Terminals		
Weight	Transmitter : 13.3oz (380g) Receiver : 14oz (400g)		
Appearance	PC resin (wine red)		

The specifications are subject to change without notice.

9 EXTERNAL DIMENSIONS

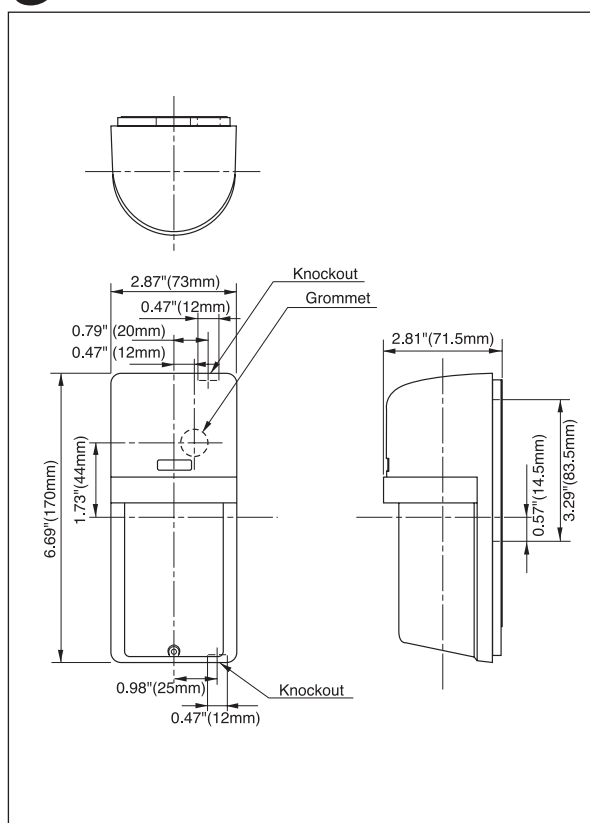

Limited Warranty :

TAKEX products are warranted to be free from defects in material and workmanship for 12 months from original date of shipment. Our warranty does not cover damage or failure caused by Acts of God, abuse, misuse, abnormal usage, faulty installation, improper maintenance or any repairs other than those provided by TAKEX. All implied warranties with respect to TAKEX, including implied warranties for merchantability and implied warranties for fitness, are limited in duration to 12 months from original date of shipment. During the Warranty Period, TAKEX will repair or replace, at its sole option, free of charge, any defective parts returned prepaid. Please provide the model number of the products, original date of shipment and nature of difficulty being experienced. There will be charges rendered for product repairs made after our Warranty period has expired.



In Japan
Takenaka Engineering Co., Ltd.
 83-1, Gojo-sotokan, Higashino,
 Yamashina-ku, Kyoto 607-8156, Japan
 Tel : 81-75-501-6651
 Fax : 81-75-593-3816
<http://www.takex-eng.co.jp/>

In the U.S.
Takex America Inc.
 230E, Caribbean Drive
 Sunnyvale, CA 94086, U.S.A.
 Tel : 408-747-0100
 Fax : 408-734-1100
<http://www.takex.com>

In Australia
Takex America Inc.
 Unit 16/35 Garden Road, Clayton,
 3168 Victoria, Australia
 Tel : 03-9546-0533
 Fax : 03-9547-9450

Takex America Inc.
 Brisbane office : 1/50 Logan
 Road, Woolloongabba
 Queensland 4102, Australia
 Tel : 07-3891-3344
 Fax : 07-3891-3355

In the U.K.
Takex Europe Ltd.
 Takex House, Aviary Court, Wade Road,
 Basingstoke, Hampshire. RG24 8PE, U.K.
 Tel : (+44) 01256-475555
 Fax : (+44) 01256-466268
<http://www.takexurope.com>