

FIRETRAX PROFESSIONAL

CONVENTIONAL FIRE ALARM CONTROL PANEL



Engineer / Installation Manual

Ventcroft Ltd
VFT-PFP 1/2/4/6/8 Conventional Fire Alarm Control Panel Engineer / Installation Manual

First Printed: 09/03/03
Document : ???
Revision: 48.0.18
Last Revised : 12/4/03

Copyright © 2003 by Ventcroft Ltd. All rights reserved. No part of this manual may be reproduced or transmitted in any form or by any means, electronic or mechanical, including photocopying, recording, or by any information storage or retrieval system, without prior written permission from the publisher.

Notice of Liability

Every effort has been made to ensure that this manual / instructions contains accurate and current information. However, Ventcroft Ltd shall not be liable for any loss or damage suffered by the readers as a result of information held herein.

Trademarks.

Ventcroft and the Ventcroft logo / device are trademarks of Ventcroft Ltd.
All other trademarks are acknowledged as trademarks of their respective companies.

Ventcroft Ltd
Goddard Road
Astmoor Industrial Estate
Runcorn, Cheshire,
WA7 1NQ, United Kingdom
Tel: +44 (0)1928 581098
Fax: +44 (0)1028 581099
Email: sales@ventcroft.co.uk
Web: <http://www.ventcroft.co.uk>

If you have a questions about this product please do not hesitate to ring,
Technical Help: +44 (0)1928 581098

Table of Contents

1.0 DESCRIPTION	4
2.0 FEATURES	4
3.0 KIT CONTENTS	4
4.0 TECHNICAL DESCRIPTION.....	5
4.1 Electronics Cassette Layout	5
4.2 Fire Panel Field Terminals Description	5
4.3 Front mounted LED Descriptions.....	6
4.4 External Controls	6
4.4 Internal Controls	7
4.5 Internal Features (Inside Electronics Cassette)	7
4.6 Internal Safety Fuses and Current Limiting.....	7
5.0 Installation	8
5.1 System Design	8
5.2 Fire Control Panel Enclosure	8
5.3 First Fix.....	10
5.4 Pre-Connection Checks.....	13
5.5 Commissioning	14
6.0 Programming	17
6.1 Overview of the panel's external controls.	17
6.2 Enabling Engineer Options	18
6.3 Programming Repeater Panels.	19
7.0 Fault Finding.....	20
7.1 Fault Overview.....	20
7.2 Detailed Fault Finding.....	21
Appendix	24
i: Stand-by battery calculation guide.....	24
ii: EOL Devices	25
iii: Detector Base and Call Point Wiring Information.	26
iv: System Configuration Data	27
8.0 Specifications.	28

1.0 DESCRIPTION

The Professional range of conventional fire alarm control panels has been designed to be fully compliant with EN54-2:1997 and EN54-4:1997 and provide 1 to 8 zones of detection.

2.0 FEATURES

The main features of the panel include:-

- One, two, four, six or eight zones of detection (Model Dependant)
- Two conventional sounder circuits, fully monitored
- 1 Amp total sounder current
- Single 12V battery backup operation (With space for 2 x 7AHr VRLA batteries)
- Class Change
- Keypad access code with Keyswitch option
- Keypad Disable
- Programmable non-latching zone for networking
- Fire or Fault Relay
- Fully monitored fire output
- One man walk test feature
- Current saving zone disable
- Zone Short equals Fire option
- Electronics Cassette
- Metal Back Box (33 x 20mm Cable Entry Holes)
- Head Removal Detection (Requires Schottky Diode Bases)

3.0 KIT CONTENTS

Contents

1	x	Professional Firetrax Conventional Control Panel
1-8	x	10 μ F 36v End of Line Capacitors
3	x	6K8 Ω End of Line Resistors
1	x	Engineer/Installation Manual
1	x	User manual/Log Book
1	x	Quick Start Engineer Guide
1	x	Quick Start User Guide
1	x	Battery Leads
1	x	Spares Kit
		Comprising Of:-
		1 x 20mm Fuse
		2 x 10 μ F 36v End of Line Capacitor
		2 x 6K8 Ω End of Line Resistors
		1 x 470 Ω Resistor
		2 x Battery retainers

4.0 TECHNICAL DESCRIPTION

4.1 Electronics Cassette Layout

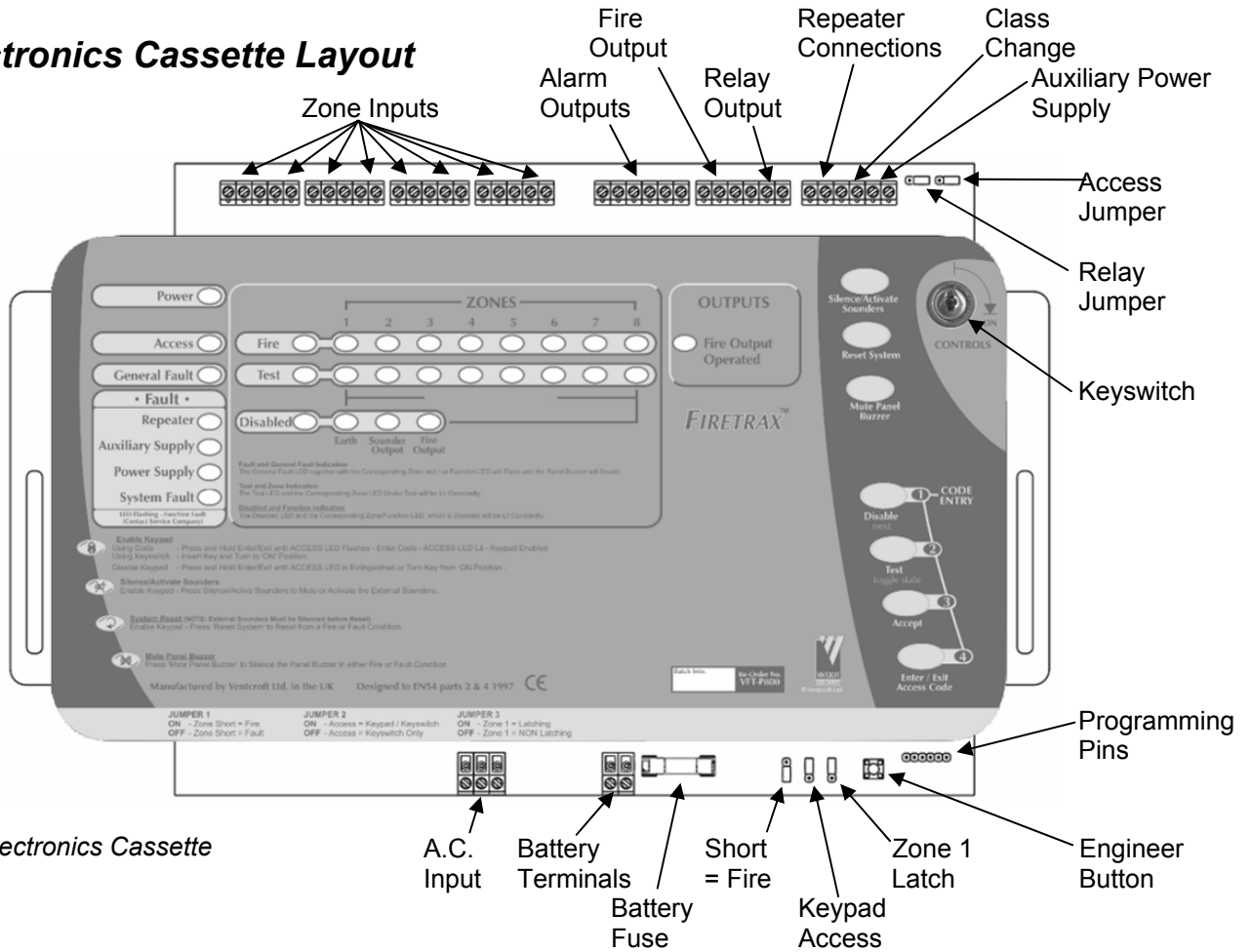

Figure 1: Electronics Cassette

4.2 Fire Panel Field Terminals Description

Section	Legend	Terminal Numbers	Description
ZONE 1-8	+	1,4,6 etc	The zone terminals + and - are used to connect to either manual or automatic fire detection devices such as manual call points or smoke detectors and are fully monitored for open/short circuit and detector head removal. The ⊥ terminal is used to connect the drain or cpc core of the screened cable.
	-	2,5,7etc	
	⊥	3,8,13 etc	
ALARM 1-2	+	21,24	The Alarm terminals + and – are used to connect fire sounders and are fully monitored for open/short circuit detection. The ⊥ terminal is used to connect the drain or cpc core of the screened cable.
	-	22,25	
	⊥	23	
FIRE OUTPUT	+	27	The Fire Output terminals + and – are used to connect external warning or routing devices and are fully monitored for open/short circuit detection. The ⊥ terminal is used to connect the drain or cpc core of the screened cable.
	-	28	
	⊥	29	
RELAY OUTPUT	N/O	30	These are volt free contacts capable of switching 3 Amps @ 30VDC or 3 Amps @ 125VAC. This relay can be configured to switch on either a Fire or Fault activation.
	C	31	
	N/C	32	
REPEATER	0v	33	These connections are for the external repeater panels, up to 8 repeater panels (Active or passive) can be connected to this system. NOTE: this may affect the standby battery time.
	DATA	34	
	+24v	35	
CLASS CHANGE	CC	36	A switched 0v will allow a remote source to operate the sounders.
AUX 24V	0V	37	The AUX 24v terminals provide a 24v polyfused output to drive external devices. Please check with the specifications for the maximum supply current. NOTE: this may affect the standby battery time.
	+24V	38	
AC	~	39	The ~ terminals are used to connect the 17v A.C. from the mains transformer The ⊥ terminal is used to connect the Earth wire. These connections are pre-wired to a removable 3 way terminal block.
	~	40	
	⊥	41	
12V BATTERY	+	42	The battery terminals are use for connection to the standby backup battery. These connections are already pre-wired to a removable 2 way terminal block.
	-	43	

4.3 Front mounted LED Descriptions

4.3.1 LED Display Types Quick Reference Guide

The Professional Fire Panel has various status LED's to provide user feedback on the status of the fire panel.

The Green LED is relating to the condition of the power supply, Red LED's so if the fire panel is in a fire condition and the Yellow LED's show Fault, Test or Disablement.

4.3.2 LED Descriptions

	LED	Colour	Description
	Power	<i>Green</i>	Status of the power supply
	Access	<i>Yellow</i>	Code Entry/ Access Level 2 Granted
FIRE	Fire	<i>Red</i>	Fire Detected on one of the zones
	Zones(1-8)	<i>Red</i>	Zone in Fire
	Fire Output	<i>Red</i>	Fire Output operated
FAULT/TEST/DISABLED	General Fault	<i>Yellow</i>	Fault Detected on one of the features below
	Repeater	<i>Yellow</i>	Communication Lost with repeater panel, or in setup mode
	Auxiliary Supply	<i>Yellow</i>	Auxiliary supply fault
	Power Supply	<i>Yellow</i>	Power Supply fault, 24V, 16V, 13.8V, 5V, Battery or Mains Supply
	System Fault	<i>Yellow</i>	System Fault detected. System or Site data corrupt
	Zones (1-8)	<i>Yellow</i>	Zone in Fault, Test or Disabled or currently being set-up
	Test	<i>Yellow</i>	A zone has been put in Test or currently being set-up
	Disabled	<i>Yellow</i>	A zone has been Disabled or currently being set-up
	Earth	<i>Yellow</i>	Earth fault has been Detected or Disabled or currently being set-up
	Alarm	<i>Yellow</i>	Sounders fault Detected/Disabled or currently being set-up
	Fire Output	<i>Yellow</i>	Fire Output Fault Detected/Disabled or currently being set-up

4.4 External Controls

There are several buttons which control the operation of the fire panel on the front of the fire panel case. These controls are available from various levels: Level 1 or Level 2 (User Access)

4.4.1 Button Descriptions

Button	Description
Silence/Activate Sounders	Silence/ Activate the Sounders. (Level 2)
Mute Panel Buzzer	Mute the internal buzzer in either fire or quiescent mode and in any access level.
Reset System	This key will reset the fire panel from either a fire or a fault condition. (Level 2)
Disable/Next/1	Enter Disablements mode/Scroll through options/Code Entry
Test/Toggle/2	Test Display or Enter Test mode/Toggle feature/Code Entry
Accept/3	Accept feature/Code Entry
Code/Exit/4	Initiate Code entry/Exit out of Option/Code Entry
Keyswitch	Keyswitch to Enable Access Level 2 (Optional)

4.4 Internal Controls

The following controls are only available from access level 3 (Engineer Access)

4.4.1 Jumper/Button Descriptions

Control	Description	Notes See Section
Engineer Button	This is used to set-up the repeater panels.	6.2.1
Access Jumper	Enables the bypass of code entry for level 2 access	6.2.2
Relay Jumper	Selects the action of the onboard relay from Fire or Fault activation	6.2.3[‡]
Zone 1 Latch	Enables Zone 1 to be latching or Non-Latching	6.2.4
Keypad Access	Enables or Disables Access to Level 2 via the keypad code entry	6.2.5
Short = Fire	Globally enables a short on a zone to give a Fire not Fault activation.	6.2.6[‡]

[‡] Please read relevant notes as this option may change EN54 compliance.

4.5 Internal Features (Inside Electronics Cassette)

4.5.1 Internal Buzzer

This buzzer will operate during a fire, fault and test. The buzzer may be muted by pressing the Mute Buzzer button, this will silence all current activations, and the buzzer will resound on subsequent activations.

4.5.2 Internal Relay

This relay is selectable between Fire and Fault output via a jumper (See **Internal Controls** above).

4.6 Internal Safety Fuses and Current Limiting

The Firetrax Professional fire control panel has seven internal safety fuses to protect the sensitive electronics from external current overloads short circuits and thermal transformer fuse to conform regulation to limit any change of overload and fire.

4.6.1 F1: Battery, 6.3A, Anti Surge / Timed.

The battery fuse protects the Firetrax battery supply from overload either while charging, standby or mains fail conditions.

4.6.2 F2: Auxiliary Supply Fuse, 100mA Polyfuse (Resettable)

The auxiliary supply is protected by a 100mA polyfuse. This will be tripped when excess current is drawn through the device and will automatically reset when the fault has been removed.

4.6.3 F3: Fire Output fuse, 100mA Polyfuse (Resettable)

The Fire Output is protected by a 100mA polyfuse. This will be tripped when excess current is drawn through the device and will automatically reset when the fault has been removed.

4.6.4 F4: Mains Fuse, 1 Amp 240V HRC ceramic 20mm

The Mains fuse protects the Firetrax equipment from external short circuits of faults which could cause the fire panel damage.

4.6.5 F5: Mains Transformer Thermal Fuse, 1A, 102 °C. (Non Replaceable.)

The Mains Transformer Thermal Fuse protects the transformer from overheating. The chance of this fuse blowing or breaking is very rare and highly unlikely and is circuit protection is mandatory and is non-replaceable.

4.6.6 Current Limiting: Alarm Outputs 500mA per Circuit

Both of the alarm outputs are current limited to 500mA each and will automatically reset once the short circuit has been removed.

5.0 Installation

5.1 System Design

This manual does not cover the design of a fire alarm system. Although it is assumed that you have a basic knowledge of fire system components and their correct usage before attempting to install this fire panel.

It is recommended that the design of the fire system should be completed by a qualified person and that the final system is commissioned and serviced in accordance to the specifications and national standards.

It is also recommended that you read BS 5839-1:2000 "Fire Detection and Alarm Systems for Buildings (Code of Practice for System Design, Installation and Servicing)" which is available at your local reference library or may be purchased from the BSI.

5.2 Fire Control Panel Enclosure

The Fire panel consists of three parts, the front cover, the electronics cassette and the metal back box. As shown below.

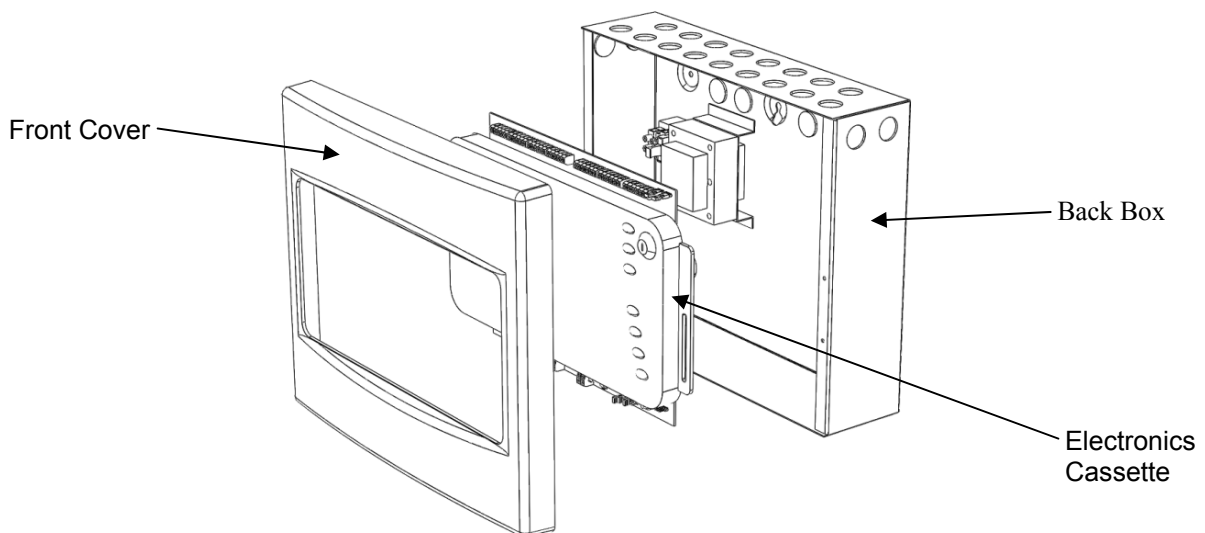

Figure 2: Exploded view of Fire Panel

NOTE:

The panel must be installed internally in such a position that it will not be affected by surrounding conditions, e.g. Extremes of Temperature, Damp, water, physical abuse, etc. Ideally it should be mounted with the LED indicators at eye level in a prominent position where it is easily accessible.

Typical locations are in the entrance hallway or foyer of a building or a security office that is permanently manned these being locations where the emergency services will go to first.

5.2.1 Front Cover

The front cover of the fire panel can be removed by means of undoing the two screws on the front face of the cover and pulling the cover away from the back box.

5.2.2 Electronics Cassette

The cassette can be removed by first removing the three terminal plug-in connector for the A.C. supply (See bottom left) and if back-up batteries are all ready connected remove the two terminal plug-in connector for the back-up batteries, then by loosening the two screws on either side of the cassette and sliding the cassette down until the screw heads are in line with the openings in the guide and pulling the cassette away from the back box.

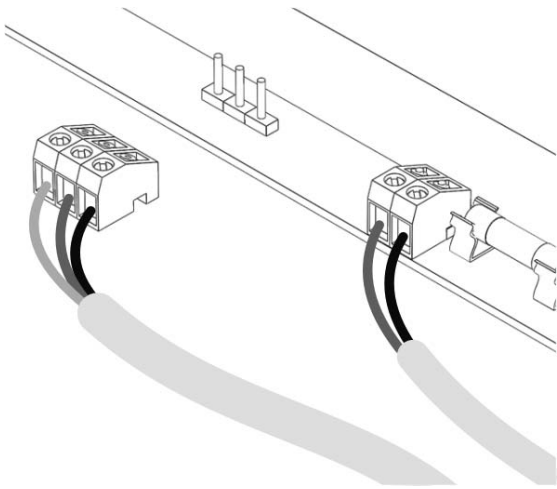

Figure 3: A.C. Input Terminal Block

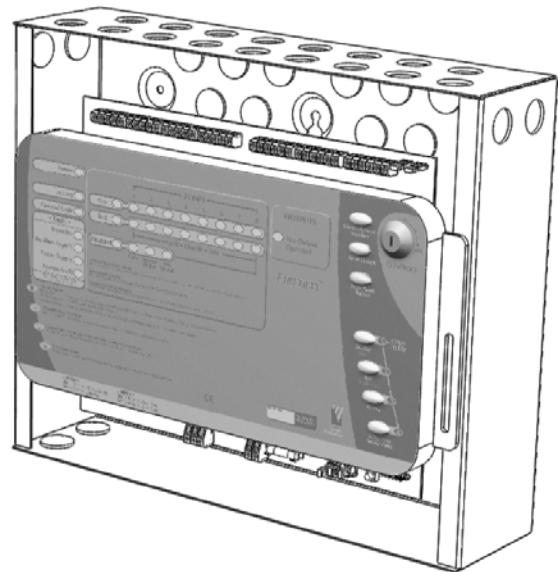

Figure 4: Electronics Cassette and back box

5.2.3 Back Box

The back box is 1.2mm powder coated zintec steel, with provision for 33 20mm cable gland entry points; it also has space to house 2 x 7Ahr SLA batteries,

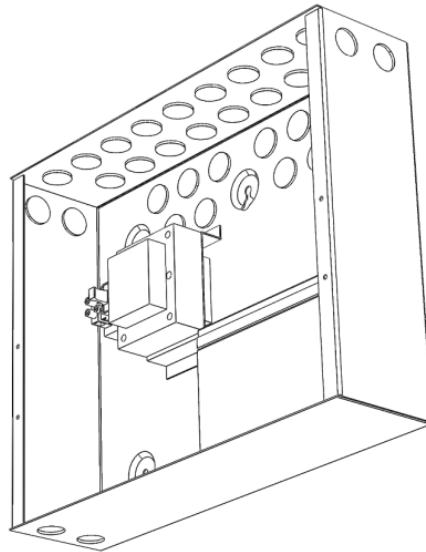

Figure 5: Back box

5.3 First Fix

All wiring should conform to BS5839-1:2002 and BS7671:2001 (Wiring Regulations) and to any national standards were applicable.

5.3.1 Introduction

This section provides instructions for installing the professional range of fire panels and field devices. It doesn't give advice on type, number and location of the equipment for a particular system; it is assumed this will have all ready been determined by a project engineer or system planner.

NOTE: THE FIRE PANEL AND FIELD DEVICES USE CMOS COMPONENTS, WHICH CAN BE DAMAGED BY STATIC DISCHARGE. SUITABLE PRECAUTIONS MUST BE TAKEN WHEN HANDLING CIRCUIT BOARDS.

5.3.2 Mounting the Back Box

Remove the front cover and the electronics cassette (See 5.2.1-5.2.2) and place them in a safe location, and mount the back box onto the wall. There are 5 mounting holes (see figure 6 below) in the back box through which you can securely mount the back box to the wall. These mounting holes require No.10-12 or 5-5.5mm countersunk screws and suitable screw fixing dependant on the condition and construction of the wall.

The top centre hole is a keyhole this allows the back box to be hung and levelled before the remaining holes are marked. There is a template on the back of the fire panel shipping carton to help with installation. Care must be taken to remove and dust and swarf from the interior of the back box.

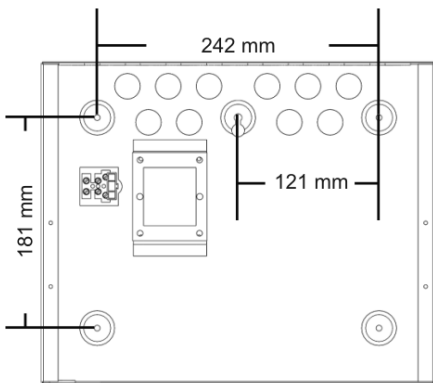

Figure 6: Back box mounting holes

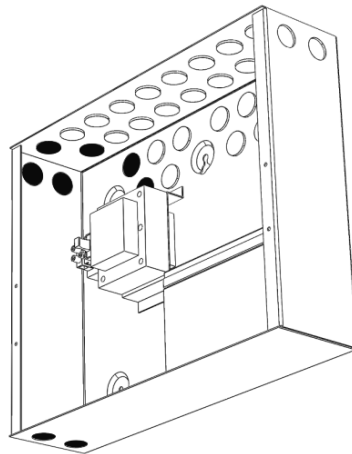

Figure 7: Knockouts for mains use

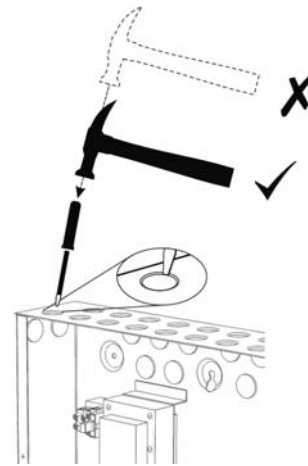

Figure 8: How to remove knockouts

5.3.3 Cable Installation

Cables should be in accordance with BS5839-1:2002, they should be brought into the back box through the top, bottom, left, right or rear knockouts provided and glanded using 20mm glands. Tails of sufficient length should be left in order to connect to the relevant field terminals. Care should be taken not to damage the PCB. Field Terminals accept one 0.5mm² to 2.5 mm² stranded or solid conductor cable.

The Mains supply cable should be segregated away from all other field wiring in the fire panel, with this in mind careful planning of what knockouts are to be used is needed. The knockouts on the bottom left, left hand side and the top left two knockouts are reserved for mains cable.

5.3.4 Mains Wiring

The mains supply should be exclusive to the fire alarm panel. This should be fixed wiring using three core cable or equivalent (not less than 0.75 mm^2 and not more than 25 mm^2), fed from an isolating switched fuse spur, fused at 3A.

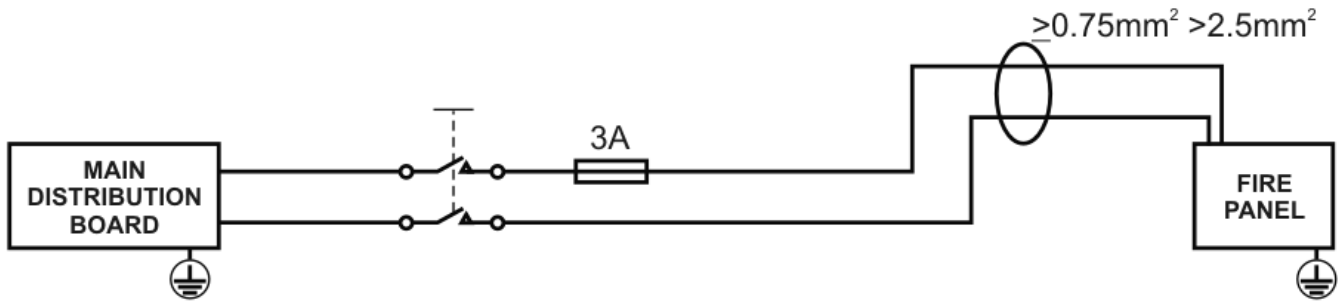

Figure 9: Mains Wiring

This fused spur should be secure from unauthorised operation and be marked with either:-

- “FIRE ALARM”
- “FIRE ALARM. DO NOT SWITCH OFF”
- “WARNING. THIS SWITCH ALSO CONTROLS THE SUPPLY TO THE FIRE ALARM SYSTEM”

5.3.5 Detector and Manual Call Point Wiring

Field Devices should be wired with a minimum of 1 mm^2 copper cables, there should be no spurs, or ‘T’ offs from the main run.

NOTE: Please refer to the specification for the maximum number of devices that may be fitted to each zone.

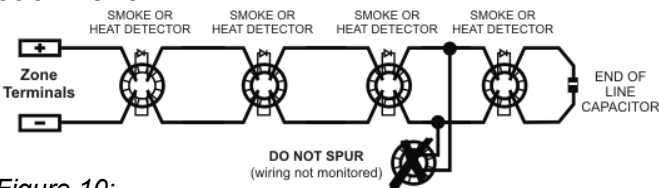

Figure 10:
Zone wiring example 1

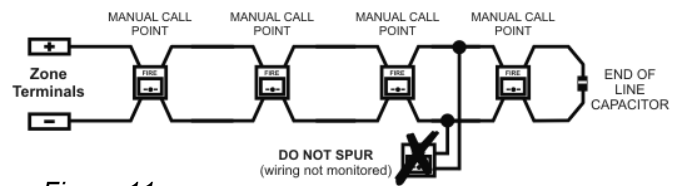

Figure 11:
Zone wiring example 2

The EOL Device must be connected across the terminals of the last device on each zone to enable head removal detection. Detector bases with integrated continuity diode to ensure manual call points will continue to work when a detector head is removed from its base (Please see note below). Manual call points with integrated resistors ($470\text{-}680\Omega$) must be used in order to prevent an activation being processed as a fault instead of a fire condition. (See **Appendix IV** for various connection details). Please refer to manufactures instructions for more detailed wiring diagrams.

NOTE: Although it is possible to connect both automatic (Smoke detectors) and manual (Call points) activation devices to the zones it is recommended that these different types are kept on individual zones.

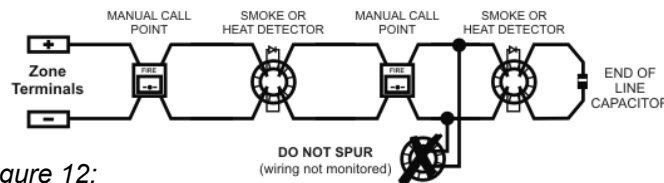

Figure 12:
Zone wiring example 3

The wiring for each zone should be connected to the relevant terminal on the control panel and their screens connected to the \perp terminal.

NOTE: Please observe the polarity of the connections.

5.3.6 Networking with Zone 1

In order to network multiple fire panels together Zone 1 is set to non-latching (See **4.4 Internal Controls**), and the following circuit is used:-

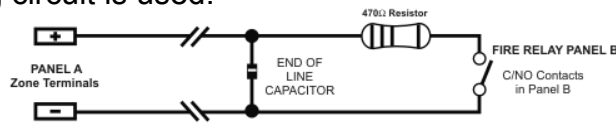

Figure 13: Zone1Network Wiring

As soon as the auxiliary fire relay contacts close on panel B it will cause Panel A to go into a fire condition immediately, when the fire condition on Panel B is cleared the fire condition on Panel A will be cleared. This stops the lockup problem if both panels are networked with connections in both directions.

5.3.7 Sounder Wiring

Two conventional sounder circuits are available which can supply a total of 1 Amp (500mA per circuit). All sounders must be polarised versions; non-polarised sounder will show as a sounder fault on the control panel.

A 6k8Ω resistor must be fitted in the last sounder in each of the alarm circuits to enable correct monitoring of the alarm circuits. Please refer the manufactures instructions for details wiring descriptions.

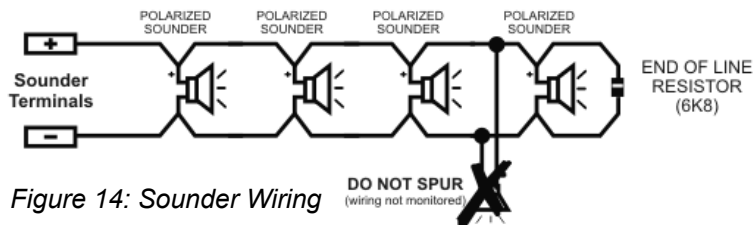

Figure 14: Sounder Wiring

The wiring for each alarm circuit should be connected to the relevant terminal on the control panel and their screens connected to the ⊥ terminal. *Note: Please observe the polarity of the connections.*

A relay may be connected on the sounder circuit providing that two diodes are fitted as shown below. The relay must have a 24V DC coil.

Note: EN 54-4:1998 states that all sounder output circuits must be monitored by adding this relay you will bypass this fault monitoring.

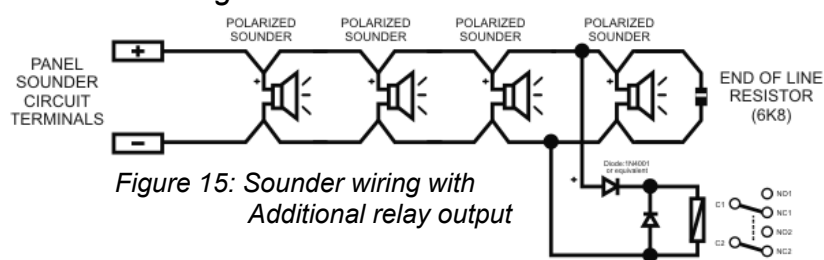

Figure 15: Sounder wiring with Additional relay output

5.3.8 Fire Output Wiring

The fire output circuits can supply a total of 100mA. Any external devices connected to the fire output must be polarised; non-polarised devices will show as a fire output fault on the control panel.

A 6k8Ω resistor must be fitted in the last device in the fire output circuit to enable correct monitoring of the circuit.

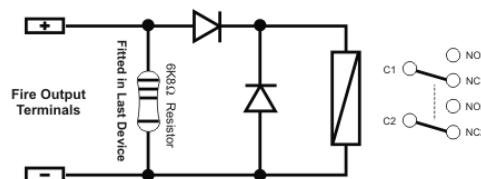

Figure 16: Example of a relay connected to the fire Output

5.3.9 Relay Output Wiring

A volt free set of relay contacts are available for switching various external devices. These are able to switch up to 3 Amps @ 30VDC or 3 Amps @125VAC. This relay can be configured to switch state on either fire activation or fault activation via a jumper (See 4.4 Internal Controls).

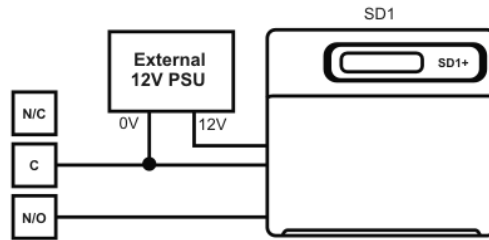

Figure 17: Example of a SD1 speech dialler connected to the fire Output

5.3.10 Class Change Wiring

If this terminal is wired to an auxiliary 0V it will cause the sounders to active continuously while the connection is applied. The Fire Output will not be activated.

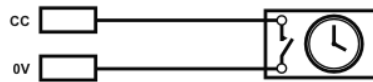

Figure 18: Example of a timed contact connected to the class change inputs

5.3.11 Repeater Wiring

Up to eight active/passive repeaters may be added to the fire control system.

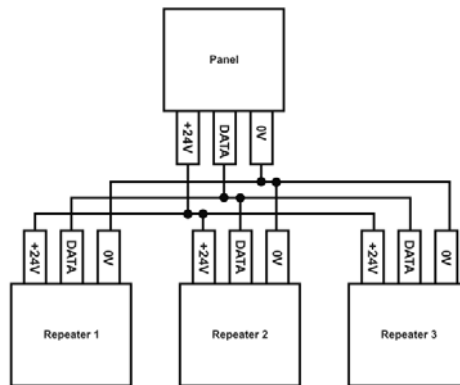

Figure 19: Example of repeater panel wiring

5.3.12 Auxiliary 24V

This provides a 24V supply for external loads; it is able to supply a maximum of 100mA. Any current drawn from this auxiliary supply must be taken in to account when calculating the standby battery size.

Note: It is not recommended to power door closures from these terminals

5.4 Pre-Connection Checks

Before connecting to the panel all wiring should be checked, the field wiring should be checked for insulation, continuity, earth faults and short circuits etc. Connect the EOL capacitor (End of Line) across the last device in each of the zone wiring runs and the EOL resistor across the sounder circuits and fire output runs. Then connect all field devices, once connected **DO NOT USE A HIGH VOLTAGE MEGGER** to test the circuitry; only low voltage meters or equivalent should be used. Using a multi-meter verify that all zone, sounder and fire output circuits EOL devices can be seen. If a zone, sounder or fire output circuit is not used the EOL device should be left fitted in the panel field terminals.

5.5 Commissioning

WARNING: Damage may occur by connecting cables to the panel while the panel is powered. Ensure this section has been read and understood before attempting to commission the panel.

5.5.1 Introduction

Commissioning the fire panel involves the following procedures:-

- Connecting Field devices and external wiring
- Configuring hardware settings
- Powering the panel
- Testing the system

In order to avoid unnecessary problems this procedure should be completed in a logical step by step order and each step being verified that it is correct before attempting the next step.

Before connecting the field devices, it is recommended that the panel is powered up and checked for correct operation.

5.5.2 Connecting the Mains

Before starting ensure that the fire panel back box is earthed and that the mains supply is isolated. The incoming mains cable should be brought through the back box by either the bottom left hand knockouts, top left hand side knockouts or by top left knockout (See 5.3.3). This should then be terminated to CON1 at the left of the transformer. (See *figure 21*)

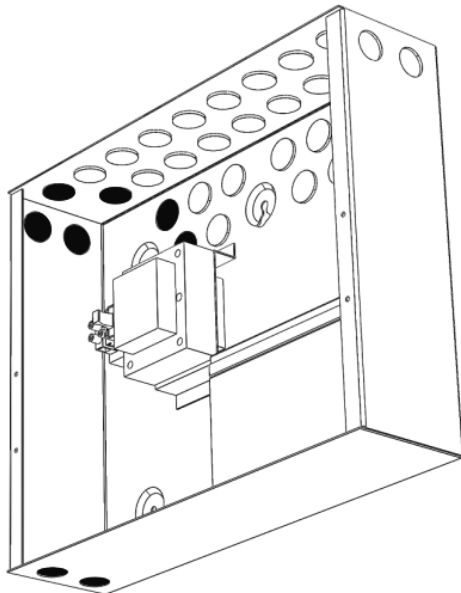

Figure 20: Recommended mains entry points.

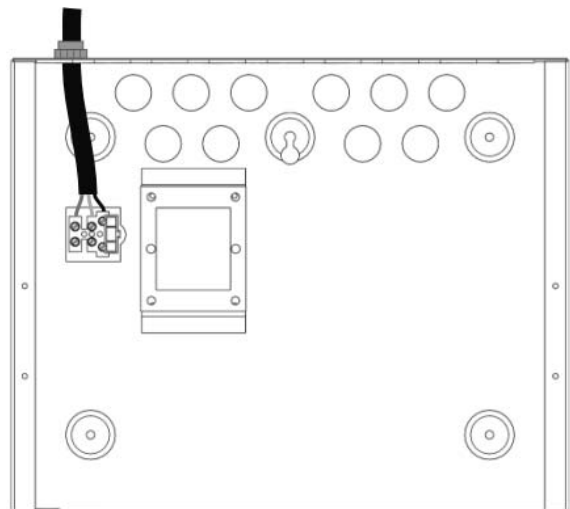

Figure 21: Example of mains wiring.

5.5.3 Connecting the back-up batteries

The professional series of fire panels only requires a single 12v sealed valve regulated lead acid battery in order to maintain correct working. A new fully charged battery should be fitted in the back box as shown below left. The plug-in connector with the battery leads should be removed from the electronics cassette and the battery leads connected to the backup battery (Please ensure that the polarity of the leads are correct).

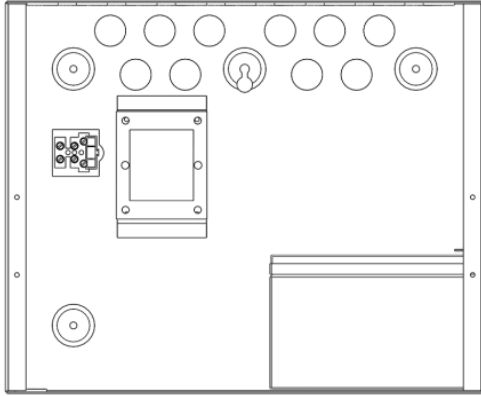

Figure 22: Example of a single 7.0 AHr battery

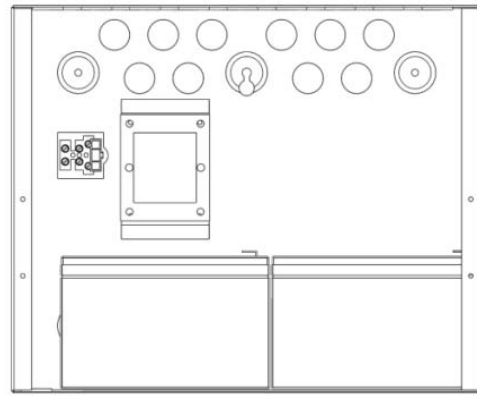

Figure 23: Example of two 7.0 AHr batteries

The fire panel incorporates a sophisticated battery charge and monitoring circuit, this ensure correct charging over varying temperatures and prevents deep discharge of the battery in mains fail condition. If a battery is not fitted, discharged or damaged the fire panel will show a PSU fault.

The capacity of this battery will depend upon the stand-by time, to calculate this battery capacity please refer to **Appendix i**. If you require a larger capacity than then two of the same capacity batteries can be placed in parallel.

NOTE: Please ensure if two batteries are used that they are from the same manufacturer and have the same capacity.

5.5.4 Connecting the Electronics Cassette

Ensure all EOL devices are in place for the zones, sounder and fire output circuits. Place the electronics cassette up to the back box lining up the holes in the guide rails with the bolts in the back box.

5.5.5 Initial Power Up and Test

1. Connect the three terminal plug-in A.C. connector into the electronics cassette.
2. Switch on the Mains supply
3. All LED's should light and the internal buzzer will sound
4. Only the Power (Flashing), General Fault and the PSU Fault should remain lit.
5. The internal Buzzer will still be sounding. **NOTE:** This may be muted by pressing Mute Panel Buzzer.
6. If any other LED's are lit or abnormal conditions indicated, these should be investigated and rectified before proceeding. See **7.0 Fault Finding**.
7. Connect the two terminal plug-in Battery connector into the electronics cassette.
8. The Power Led should go constant and the General and PSU fault LED should go out.
9. If any other LED's are lit or abnormal conditions indicated, these should be investigated and rectified before proceeding. See **7.0 Fault Finding**.
10. Switch of the Mains Supply and remove the Battery plug-in connector.

5.5.6 Connecting the Detectors

1. Remove the EOL device from the first Zone terminals, and connect it to the last device on that Zone. (Please observe the polarity: See *Appendix ii – EOL Devices*).
2. Connect the external wiring into the zone terminals in the control panel (Please observe correct polarity for zone and connect the screen to the \perp terminal)
3. Check correct operation of control panel follow procedure **5.5.5** above.
4. Repeat steps 1-3 for each of the zones to be connected, if any zones are left unused leave the EOL device in the zone terminals in the control panel.

5.5.7 Connecting the Sounder Circuits

1. Remove the EOL device from the first Alarm terminals, and connect it to the last device on that circuit (Please observe the polarity: See *Appendix ii – EOL Devices*).
2. Connect the external wiring into the Alarm terminals in the control panel (Please observe correct polarity for zone and connect the screen to the \perp terminal)
3. Check correct operation of control panel follow procedure **5.5.5** above.
4. Repeat steps 1-3 for the other Sounder circuit.

5.5.8 Connecting the Fire Output Circuit

1. Remove the EOL device from the Fire Output terminals, and connect it to the last device on that circuit (Please observe the polarity: See *Appendix ii – EOL Devices*).
2. Connect the external wiring into the Fire Output terminals in the control panel (Please observe correct polarity for zone and connect the screen to the \perp terminal)
3. Check correct operation of control panel follow procedure **5.5.5** above.

5.5.9 Connecting the Relay

1. Connect the external wiring to the required terminals (N/O, C, N/C). Please ensure you do not exceed the current rating of the relay contacts
2. Check correct operation of control panel follow procedure **5.5.5** above.

5.5.10 Connecting Repeater Panel

1. Connect the external wiring to the repeater terminals (0V, DATA, 24V). Please ensure the connections are correct.
2. Check correct operation of control panel follow procedure **5.5.5** above.

5.5.11 Connecting Class Change

1. Connect the external wiring to the required terminals (CC, 0V). Please ensure that a volt free switch or contact is used.
2. Check correct operation of control panel follow procedure **5.5.5** above.

5.6 Replace the Front Panel

Ensure all the jumpers are in the correct positions and the Access jumper is in the keeper position. If the electronics cassette has been lowered to aid cable installation this should be pushed up to its top position and the two bolts tightened. The front panel can now be replaced and the final two bolts tightened up.

6.0 Programming

6.1 Overview of the panel's external controls.

On the professional range of fire panels there are three levels of access:

- Level 1 (General User)
- Level 2 (Authorised User)
- Level 3 (Engineer)

The functions of each of these levels are detailed below.

6.1.1 General User (Access Level 1)

This is the normal state for the fire panel, the LED's give a complete overview of the current status of the system; the display clearly shows any zones in fire or fault condition as well as any zones or outputs that are currently disabled or in test.

The only functions that are available at this level are:-

- Mute the panel buzzer
- Test the Led display and panel buzzer
- Code Entry to gain Level 2 access

6.1.2 Authorised User (Access Level 2)

Access to this level of controls is limited via entering the code 2143 (or turning the keyswitch to the ON position); this is required to stop unauthorised changes to critical functions of the fire alarm.

The following functions are available at this access level:-

- Silence the sounders
- Resetting the panel from a fire condition
- Manually activating the sounders (To perform a routine test or evacuate the building)
- Putting/Removing a zone from test
- Disabling/Enabling any (or all) of the following:
Zones, Earth faults, Sounders or the Fire output

For details on the above functions and there correct operation please refer to the USER GUIDE.

6.1.3 Engineer (Access Level 3)

Access to this level is gained by the removal of the front cover. The following controls should only be changed by competent service personnel.

- Override Access Required
- Relay Activation Selection
- Zone 1 Latching/Non-Latching
- Keypad Access Disabled
- Short=Fire Enabled
- Program Repeater Panels

The following section will detail the above features and how they can be enabled or disabled.

6.2 Enabling Engineer Options

6.2.1 Engineer Button

This button allows the engineer to enter engineer mode. And will scroll through the available options.

6.2.2 Access Jumper

This is a two position jumper which gives the engineer the option to bypass the need to enter the user code to gain access to Level 2. This is useful during the commissioning of a fire panel.

Access Jumper	ACCESS	This jumper can be used to permanently enable the keypad while the engineer is working on the fire panel. NOTE: This jumper must be placed back in the keeper position before the fire panel cover is replaced.
	KEEPER	This is the default place for this jumper, and must be replaced here before the panel installation is finished.

6.2.3 Relay Jumper

This jumper controls the function of the onboard relay; the relay can be switched on either a fire condition or a fault condition.

Relay Jumper	FIRE	With the jumper in this position the relay will be de-energised during a fire condition.
	FAULT	With the jumper in this position the relay will be de-energised during a fault condition. NOTE: To comply with EN54 the jumper must be in this position.

6.2.4 Zone 1 Latch

This jumper controls the facility to turn zone 1 from latching to non-latching.

Zone 1 Latch	ON	This jumper makes zone one a latching fire zone or a non-latching fire zone. Non-latching zones can be used for networking multiple fire panels together.
	OFF	Zone 1 acts as a normal latching fire zone.

6.2.5 Keypad Access

This jumper can be used to disable code entry from the keypad; you must have the keyswitch option fitted to the panel to be able to use this option.

Keypad Access	ON	This enable level 2 access by either keypad code entry or via the keyswitch (if fitted)
	OFF	This jumper disables keypad code access to level 2 of the fire panel. This function must only be used were the keyswitch option is fitted.

6.2.6 Short=Fire

This jumper enables the use of older style smoke detectors which present a short it fire condition not the usual resistance load.

Short = Fire	ON	This option is used when the panel is connected to old style smoke detectors that apply a short to the zone in fire condition. This option is global to all the zones.
	OFF	The Fire zones act as normal: A short on a zone produces a fault condition A 230Ω to 680Ω generates a Fire condition. NOTE: To comply with EN54 the jumper must be in this position.

6.3 Programming Repeater Panels.

The following section will detail the programming and reviewing of repeater panels to the main fire control panel.

The Following Controls are used:-

	Control	Action	Description
Buttons	Engineer	Pressed	Scrolls through the available Engineer options
	Accept	Pressed	Press to enter into Repeater Program mode, Learn Mode or Review Mode
	Toggle	Pressed	To scroll the options in Repeater Program mode (Learn or Review mode)
	Exit	Pressed	To Exit out of either of the Programming modes (Learn or Review)
LED	Repeater	ON	In Engineer Mode, press accept to enter into Repeater Program Mode
		7 Off / 1 On	Learn Mode: Press ACCEPT to enter into Learn mode
		7 On / 1 Off	Review Mode: Press ACCEPT to enter into Review mode
		1 On / 1 Off	In Review Mode: Press EXIT to return to Engineer options

6.3.1 Repeater Learn Mode

1. Press Engineer button until the repeater LED is illuminated
2. Press the TOGGLE until the Learn mode is selected (Learn Mode = Repeater LED will flash 7 OFF/1 ON)
3. Press ACCEPT to enter Learn Mode.
4. The panel will then search for Repeater Panels connected to the fire control panel.
 - a. If the panel finds any repeater panels it will give 2 beeps and advance back to Engineer options with Review mode highlighted.
 - b. If no repeaters are found the panel will give a long beep and return to Engineer options with Learn mode highlighted.
5. Press EXIT to leave Engineer options.

6.3.2 Repeater Review Mode

1. Press Engineer button until the repeater LED is illuminated
2. Press the TOGGLE until the Review is selected (Review Mode = Repeater LED will flash 7 ON/1 OFF)
3. Press ACCEPT to enter Review Mode.
4. The repeater LED will then flash 1 ON/1 OFF to display your in Repeater Review Mode.
5. If any repeaters have been programmed into the fire control panel the Fault LED on zone 1 will illuminate.
6. Zone 1 Fire LED will then flash to show the number of repeaters currently programmed into the fire control panel followed by a 5 second gap before repeating then number of programmed repeaters.
7. Press EXIT to return to Engineer options.
8. Press EXIT to leave Engineer options.

6.3.3 Check All Repeaters

After programming the fire control panel with repeater panels you should review the number of repeater panels that the system has programmed in corresponds to the number of repeater panels you have installed. If there is a discrepancy check that each of the repeater panels are not showing any communication faults.

7.0 Fault Finding

When the fire control panel detects a fault in a critical part of the system it will illuminate the General Fault and the corresponding Fault LED, the internal buzzer will sound and if configured the fault relay will activate.

The following section will give a brief overview of the faults followed by a detailed description and solutions for remedying the fault.

Upon detection of a fault the internal buzzer may be silenced from any Access Level by pressing the Mute Panel Buzzer button (see **4.5.1**). All faults with the exception of a mains fault are latching faults requiring a panel reset, mains faults will automatically be reset when the fault is removed.

7.1 Fault Overview

The following section gives a brief overview of system faults.

7.1.1 General

When the fire control panel detects a fault within the system, the General Fault LED will start to flash along with the corresponding fault LED.

7.1.2 Zone

All of the zones on the fire control panel are constantly monitored for head removal, open and short circuit. Once a fault is detected on a zone the relevant zone fault Led will illuminate (Unless the zone is in test or has been disabled). See **7.2.1** for detailed Zone fault finding

7.1.3 Repeater

This Led illuminates when the fire control panel cannot communicate to one or more of the repeater panels. See **7.2.2** for detailed repeater panel fault finding

7.1.4 Auxiliary

This Led illuminates when either too much current is drawn or the auxiliary supply is shorted out. See **7.2.3** for detailed Auxiliary power supply fault finding

7.1.5 Power Supply

The Power supply fault Led illuminates when there is a fault on the battery charge circuit, 24/28V supply, 16V supply, 13.8V supply, or the 5v supply or when the battery or mains is removed. See **7.2.4** for detailed Power Supply fault finding

7.1.6 System

The system fault illuminates when there is one of the following faults: - Watchdog timeout, Site or program memory has become corrupted, or there is a fault on the fire control panel circuit board. See **7.2.5** for detailed System fault finding

7.1.7 Earth

This fault will occur when a connection is made between earth and one of the transmission paths to the fire control panel. See **7.2.6** for detailed Earth fault finding

7.1.8 Sounder Output

This illuminates if a fault is detected on one of the sounder circuits either open or short circuit. These are constantly monitored in quiescent and in fire alarm condition. See **7.2.7** for detailed sounder Output fault finding

7.1.9 Fire Output

This Led illuminates when either an open or short circuit is detected on the Fire Output cabling or devices connected to the terminals.

See 7.2.8 for detailed Fire Output fault finding

7.2 Detailed Fault Finding

The following section gives a detailed description of the fault and the steps needed to be taken to remedy the fault.

7.2.1 Zone Faults.

- 1) Visually check all detectors on the zone to ensure all smoke heads are fitted and correctly seated on their bases. Replace or reseat any smoke detector heads and reset the panel, continue if fault remains.
- 2) Remove the wiring for that zone from the panel and refit the EOL device into the control panel zone terminals.
- 3) Reset the fire panel and check if the fault is removed.
- 4) If the fault is removed then the fault is on the wiring, continue to step 6
- 5) If the fault continues the fault is in the fire panel. Please contact Ventcroft Ltd. Technical Support.

- 6) Remove the EOL device from the control panel terminals and reconnect the zone wiring.
- 7) Select the first device from the fire control panel.

- 8) Remove the output wiring to the next device and connect your EOL device across the zone wiring (see figures 24, 25).
- 9) Reset the fire control panel.
- 10) If the fault clears go to step 13.
- 11) If the fault returns there is a problem with either this detector (or call point) or the wiring that connects it.
- 12) Check this detector and the wiring connections in the base. Go to step 14 Checking Fault Type.

- 13) The fault is in the subsequent wiring; remove the EOL device and replace the output wiring in the detector, go to the next detector (or call point) on the zone wiring and repeat steps 8-10 until the fault is found.

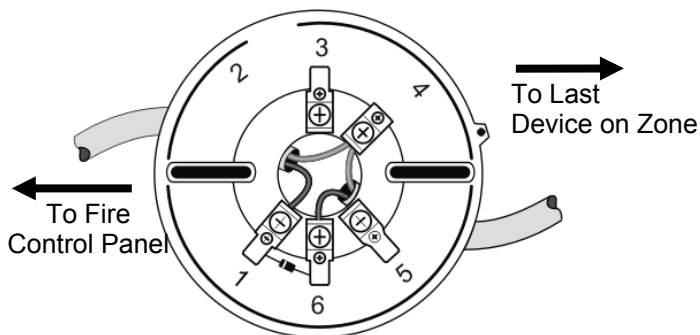

Figure 24: Fully wire detector base

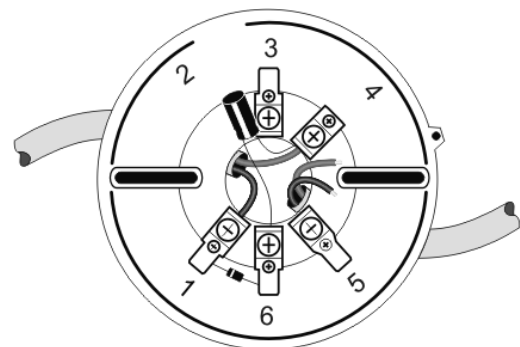

Figure 25: Detector base with output wires removed and EOL capacitor fitted.

Checking Fault Type

- 14) Remove the zone wiring from the fire control panel.
- 15) Using a multi-meter check for continuity between the + and – wires for the zone.
- 16) If you get a continuity reading then there is either a short on the cable run or in the detector. If you don't get a reading go to step 22.
- 17) Remove the detector head and check for continuity again.
- 18) If you still get a continuity reading then there is a short in either the base of the detector or in the cable connecting it. Check the wiring in the detector base and the cable run and replace which ever is necessary. Recheck continuity.
- 19) If you don't get a continuity reading then the fault is in the smoke detector head, replace the head with a new one and retest.
- 20) The fault should have now cleared remove the EOL device from this base and reconnect the output wiring to the next detector (or Call point) and replace the EOL device in the last detector (or Call point) in the zone wiring.
- 21) Go to step 30

- 22) The fault is either an open circuit in the wiring or the detector head is not fitted properly (or faulty)
- 23) Short (Connect together) the zone wires in control panel (should have been removed already in step 14)
- 24) In the detector base check for continuity between the Positive in and the Negative in terminals.
- 25) If you don't get a continuity reading then the fault is in the smoke detector head, replace the head with a new one and retest.
- 26) If you don't get a continuity reading then there is a break in the cable or incorrectly fitted in the detector base.
- 27) Recheck the connections in the base and replace the wiring from this detector to the previous one if necessary.
- 28) The fault should have now cleared remove the EOL device from this base and reconnect the output wiring to the next detector (or Call point) and replace the EOL device in the last detector (or Call point) in the zone wiring.
- 29) Remove the short between the zone wires in the control panel and replace them into the correct terminals.

- 30) Reset the control panel, the fault on this zone should be cleared. If not there was more than one fault on the cable run repeat steps 1-30.

7.2.2 Repeater Panel Faults

- 1) Visually check all of the repeater panels connected to the fire alarm control panel
- 2) On the ones that show a communications error.
 - a. Check the terminations in the repeater itself.
 - b. Check the wiring from the main panel to the repeater.

7.2.3 Auxiliary Power Supply Faults

- 1) There is a short on the wiring from the auxiliary power supply terminals or the devices attached to these terminals are drawing too much current.
 - a. Check the wiring for short circuits.
 - b. Remove external devices until the current drawn is of an acceptable level.

7.2.4 Power Supply Faults

- 1) There is a problem with one of the power supplies within the fire control panel.
 - a. Check that the mains supply is present and healthy.
 - b. Check the Isolating Fused Spur's fuse has not blown.
 - c. Check the mains terminal block fuse has not blown.

- d. Check that the backup battery is connected and healthy.
- e. Check the battery fuse has not ruptured.
- f. If the problem still persists please contact Ventcroft Ltd. Technical Help

7.2.5 System Faults

- 1) There is a problem with the system, the system site data or the system program code.
 - a. Reset the system – Check if the fault is cured
 - b. Try reprogramming a zone (i.e. disable one zone, reset the system, then re-enable that zone)
 - c. Contact Ventcroft Ltd. Technical Help

7.2.6 Earth Faults

- 1) There is a connection between earth and one of the transmission paths to the Fire control panel (i.e. one of the zones wiring is shorted to the building's metal work)
 - a. Remove all of the zone wiring, sounder wiring and any other external wiring (repeaters etc.) and replace the End of line devices in the appropriate terminals.
 - b. Reset the fire control panel – The fault should have cleared. If not contact Ventcroft Ltd. Technical Help
 - c. One at a time, replace the zone wiring and sounder wiring etc, resetting the fire control panel on each reconnection.
 - d. Check of earth faults.
 - e. Once the earth fault reappears check the wiring for that zone or sounder etc, make sure all cables and devices are free from defect and replace as necessary.

7.2.7 Sounder Output Faults

- 1) Remove the sounder wiring from all the sounder circuits in turn and using a multi-meter measure the resistance across the wires. You should see a reading equal to the EOL resistor any other value (e.g. zero ohms, open circuit or a reading too high or too low) indicates a fault on the wiring.
- 2) If all the sounder circuits' resistance measurements are good, leave the sounder circuit wiring out of the panel sounder terminals and place the EOL resistor across each of the sounder circuits. If the fault still persists then there is a fault in the panel sounder circuitry. Please consult Ventcroft Ltd. Technical support.
- 3) If the sounder fault is present only during a fire alarm then the sounder circuits are drawing too much current, check that there are not too many sounders on the circuit or that all the sounders are operating correctly.

Note: *The sounder circuits use polyfuses to protect the outputs these will reset themselves after the short circuit has been removed.*

7.2.8 Fire Output Faults

- 1) Remove the wiring from the fire output circuit and using a multi-meter measure the resistance across the wires. You should see a reading equal to the EOL resistor any other value (e.g. zero ohms, open circuit or a reading too high or too low) indicates a fault on the wiring.
- 2) If the Fire Output circuit resistance measurement is good, leave the Fire Output circuit wiring out of the panel fire output terminals and place the EOL resistor across the circuit. If the fault still persists then there is a fault in the panel Fire Output circuitry (See note below). Please consult Ventcroft Ltd. Technical support.
- 3) If the Fire Output fault is present only during a Fire Output then the Fire Output circuit is drawing too much current, check that there are not too many devices on the circuit or that all the devices are operating correctly.

Note: *The Fire Output circuit uses a polyfuse to protect the output this will reset itself after the short circuit has been removed. This may take*