

# IS-A105N/IS-L101L Intrinsically Safe Alarm Sounder & LED beacon

## Intrinsically Safe combination L.E.D beacon/light & alarm horn.

The IS-A105N+IS-L101L unit is an intrinsically safe field mounting combined alarm horn with L.E.D. beacon/light which provides a a loud audible and bright flashing visual signal utilising a common zener barrier or galvanic isolator. The alarm horn features an alarm accept function - by closing a pair of external contacts (i.e push switch) the operator may silence the alarm for set periods between 5 seconds and 2 hours. If after the preset time the alarm condition still exists the sounder will activate again. Certified for use in application requiring Ex ia or Class I Div 1 equipment the IS-A105N+IS-L101L is a globally accepted solution to fire or process control signalling.

### Features

- Input overload and reverse current protection
- Prismatic lens optimises L.E.D effectiveness
- Auto synchronised sound output
- Unit can be mounted using external lugs or internal BESA compatible fixing positions.
- Duplicate cable terminations (in & out for daisy-chain installations).
- Available with custom tone configurations and frequencies.

### Approvals

- ATEX certificate: SIRA 04ATEX2 301X,  
EN 60079-0 : 2012, EN 60079-11 : 2012,  
IEC 60079-26 : 2014
- IECEx certificate: IECEx SIR 04.0038X,  
IEC 60079-0 : 2011, IEC 60079-11 : 2011,  
IEC 60079-26 : 2014
- FM approved:  
Class 3600 1998, Class 3610 1999,  
Class 3810 2005, IEC 60529 : 1989
- GOST-R certificate: POCC GB.JB05.B03365



## Vimpex Limited

Star Lane, Great Wakering  
Essex SS3 0PJ England

Tel: +44 (0) 1702 216999

Fax: +44 (0) 1702 216699

E-mail: sales@vimpex.co.uk

[www.vimpex.co.uk](http://www.vimpex.co.uk)

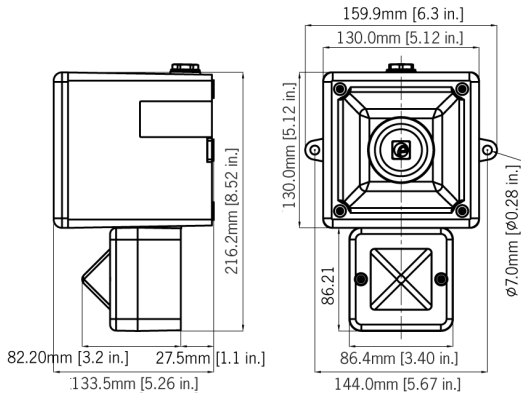

### Specification

#### Sounder/horn:

Nominal output:	105dB(A) @ 1m +/- 3dB - Tone 2* [96dB(A) @ 10ft/3m]
No. of tones:	49 (UKOOA/PFEER compliant)
No. of stages:	3
Volume control:	Max. 105dB(A); Min. 96dB(A) - Tone 2
Effective range:	60m/197ft @ 1KHz

#### Beacon/light:

Light source:	Array of 6 high intensity L.E.D's
L.E.D. colours:	Red, Amber, Blue & Green
Standalone mode:	2 Hz (2 double flashes per second)
Effective intensity cd:	48cd* - measured ref. to I.E.S.
Flash rate:	On: 1 Hz (1 double flash per second) Silenced: 2 Hz (2 double flashes per second) (alarm accepted)

#### General:

Voltage:	16-28vdc via Zener barrier or galvanic isolator
Current:	25mA typical when powered from 24v supply via 28v 300 Ohm Zener barrier
Ingress protection:	IP66
Rating:	Continuous
Housing material:	UL94V0 & 5VA FR ABS
Housing colour:	RAL3000 Red
Fixings:	Stainless Steel
Cable entries:	2 x M20 clearance gland knockouts. Custom configurations also available.
Terminals:	0.5 to 2.5mm <sup>2</sup>
Operating temp:	-40° to +60°C [-40° to +140°F]
Storage temp:	-40° to +70°C [-40° to +158°F]
Relative humidity:	90% at 20°C [68°F]
Weight:	1.15kg/2.53lbs

\*SPL data +/-3dB(A). Measured at optimum voltage.

### Part Codes

ISA105N-R

IS-L101L-R/[x]

ATEX / IECEx / FM

II 1G Ex ia IIC T4 Ga (-40°C ≤Ta≤ +60°C)

IS Class I, Zone 0, AEx ia IIC T4 Ta = +60°C

IS Class I, Division 1, Groups A, B, C, D T4

GOST-R

0ExialICT4 IP65 -40° to +60°C

[x] : LED colour R: Red, A: Amber, B: Blue, G: Green

May be powered from any certified Zener barrier or , galvanic isolator whose output parameters do not exceed :

Uo : 28VDC

Io : 93mA

Po : 1.2W

## Vimpex Limited

Star Lane, Great Wakering

Essex SS3 0PJ England

Tel: +44 (0) 1702 216999

Fax: +44 (0) 1702 216699

E-mail: sales@vimpex.co.uk

[www.vimpex.co.uk](http://www.vimpex.co.uk)

### Tone table

S 1	Description	S 2	S 3	S 1	Description	S 2	S 3
T 1	340 Hz Continuous	T 2	T 5	T 33	745Hz @ 1Hz Intermittent	T 2	T 5
T 2	800/1000Hz @ 0.25 sec Alternating	T 17	T 5	T 34	1000 & 2000Hz @ 0.5 sec Alternating - Singapore	T 38	T 45
T 3	500/1200Hz @ 0.3Hz 0.5 sec Slow Whoop	T 2	T 5	T 35	420Hz @ 0.625 sec Australian Alert	T 36	T 5
T 4	800/1000Hz @ 1Hz Sweeping	T 6	T 5	T 36	500-1200Hz 3.75sec /0.25sec. Australian Evac.	T 35	T 5
T 5	2400Hz Continuous	T 3	T 20	T 37	1000Hz Continuous - PFEER Toxic Gas	T 9	T 45
T 6	2400/2900Hz @ 7Hz Sweeping	T 7	T 5	T 38	2000Hz Continuous	T 34	T 45
T 7	2400/2900Hz @ 1Hz Sweeping	T 10	T 5	T 39	800Hz 0.25sec on, 1 sec off Intermittent	T 23	T 17
T 8	500/1200/500Hz @ 0.3Hz Sweeping	T 2	T 5	T 40	544Hz (100mS)/440Hz (400mS) - NF S 32-001	T 31	T 27
T 9	1200/500Hz @ 1Hz - DIN / PFEER P.T.A.P.	T 15	T 2	T 41	Motor Siren - slow rise to 1200 Hz	T 2	T 5
T 10	2400/2900Hz @ 2Hz Alternating	T 7	T 5	T 42	Motor Siren - slow rise to 800 Hz	T 2	T 5
T 11	1000Hz @ 1Hz Intermittent	T 2	T 5	T 43	1200 Hz Continuous	T 2	T 5
T 12	800/1000Hz @ 0.875Hz Alternating	T 4	T 5	T 44	Motor Siren - slow rise to 2400 Hz	T 2	T 5
T 13	2400Hz @ 1Hz Intermittent	T 15	T 5	T 45	1KHz 1s on, 1s off Intermittent - PFEER Gen. ...	T 38	T 34
T 14	800Hz 0.25sec on, 1 sec off Intermittent	T 4	T 5	T 46	1200/500Hz @ 1Hz - DIN / PFEER P.T.A.P.	T 47	T 37
T 15	800Hz Continuous	T 2	T 5	T 47	1KHz 1s on, 1s off Intermittent - PFEER Gen. ...	T 46	T 37
T 16	660Hz 150mS on, 150mS off Intermittent	T 18	T 5	T 48	420Hz @ 0.625 sec Australian Alert	T 49	T 5
T 17	544Hz (100mS)/440Hz (400mS) - NF S 32-001	T 2	T 27	T 49	500-1200Hz 3.75sec /0.25sec. Australian Evac.	T 26	T 37
T 18	660Hz 1.8sec on, 1.8sec off Intermittent	T 2	T 5				
T 19	1.4KHz-1.6KHz 1s, 1.6KHz-1.4KHz 0.5s -NFC48265	T 2	T 5				
T 20	660Hz Continuous	T 2	T 5				
T 21	554Hz/440Hz @ 1Hz Alternating	T 2	T 5				
T 22	544Hz @ 0.875 sec. Intermittent	T 2	T 5				
T 23	800Hz @ 2 Hz Intermittent	T 6	T 5				
T 24	800/1000Hz @ 50Hz Sweeping	T 29	T 5				
T 25	2400/2900Hz @ 50Hz Sweeping	T 29	T 5				
T 26	Bell	T 2	T 15				
T 27	554Hz Continuous	T 26	T 5				
T 28	440Hz Continuous	T 2	T 5				
T 29	800/1000Hz @ 7Hz Sweeping	T 7	T 5				
T 30	300Hz Continuous	T 2	T 5				
T 31	660/1200Hz @ 1Hz Sweeping	T 26	T 5				
T 32	Two T chime.	T 26	T 15				