

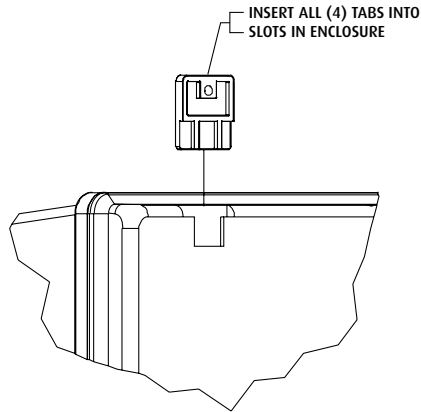

Safety Technology International, Inc.
2306 Airport Road • Waterford, Michigan 48327-1209
Phone: 248-673-9898 • Fax: 248-673-1246
Toll Free: 800-888-4784 • E-mail: info@sti-usa.com
Web: www.sti-usa.com

Safety Technology International (Europe) Ltd.
Unit 49G Pipers Road • Park Farm Industrial Estate • Redditch
Worcestershire • B98 0HU • England • Tel: 44 (0) 1527 520 999
Fax: 44 (0) 1527 501 999 • Freephone: 0800 085 1678 (UK only)
E-mail: info@sti-europe.com • Web: www.sti-europe.com

STEP 1



STEP 2

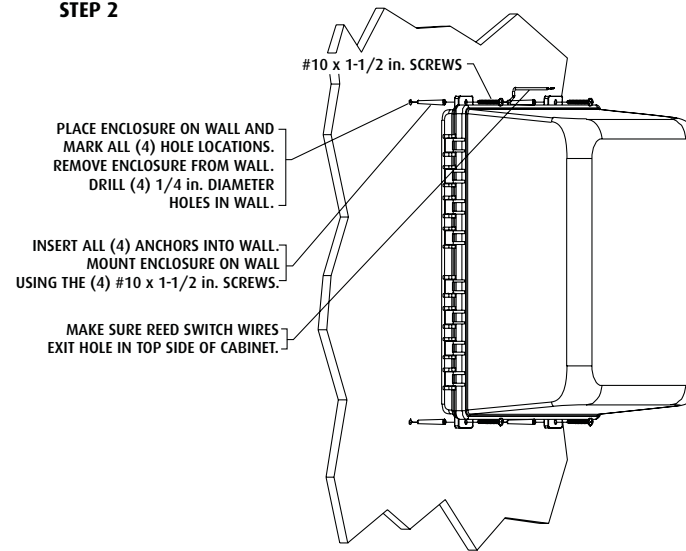

STEP 3

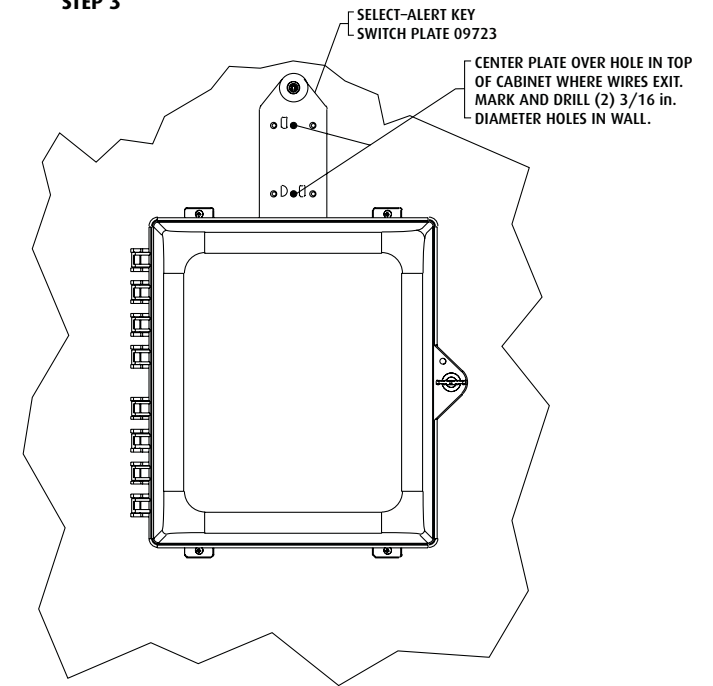

QUICK INSTALLATION OF STI-7535AED

All specifications and information shown were current as of publication, and are subject to change without notice.



Safety Technology International, Inc.
2306 Airport Road • Waterford, Michigan 48327-1209
Phone: 248-673-9898 • Fax: 248-673-1246
Toll Free: 800-888-4784 • E-mail: info@sti-usa.com
Web: www.sti-usa.com

Safety Technology International (Europe) Ltd.
Unit 49G Pipers Road • Park Farm Industrial Estate • Redditch
Worcestershire • B98 0HU • England • Tel: 44 (0) 1527 520 999
Fax: 44 (0) 1527 501 999 • Freephone: 0800 085 1678 (UK only)
E-mail: info@sti-europe.com • Web: www.sti-europe.com

STEP 4

INSTALL PLASTIC ANCHORS INTO WALL.
ROUTE KEY SWITCH AND REED SWITCH WIRES FROM BEHIND KEY SWITCH PLATE
THROUGH HOLES IN BOTH PLATES (AS SHOWN).
ATTACH BOTH PLATES TO WALL WITH (2) #8 x 1-1/4 in. SCREWS.
(BE SURE ALL WIRES ARE PROTECTED FROM VIEW BEHIND KEY SWITCH PLATE.)

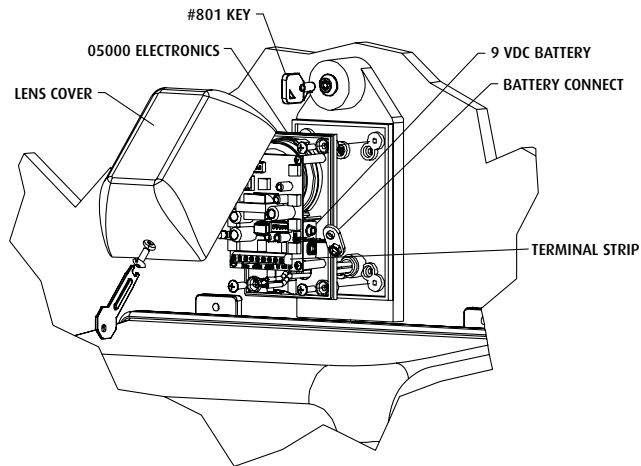
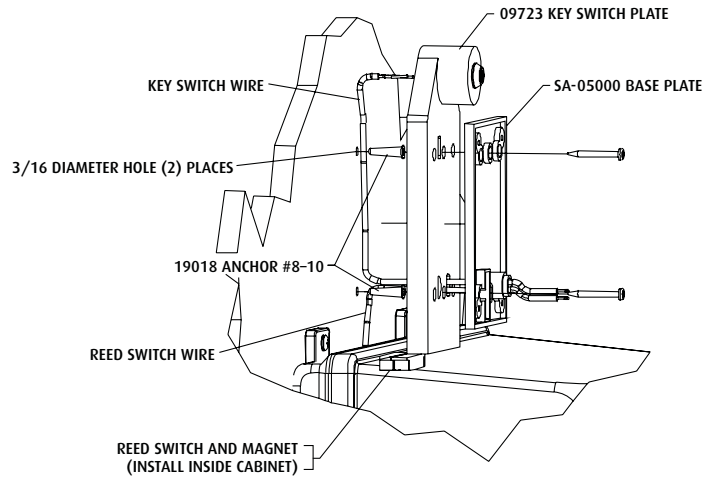

STEP 5

FEED WIRES THROUGH 05000 ELECTRONICS PLATE
MOUNT 05000 ELECTRONICS TO SA-05000 BAS PLATE.
CONNECT REED SWITCH WIRES TO TERMINAL STRIP.
CONNECT BATTERY.
INSTALL LENS COVER.
CLOSE CABINET DOOR.
TURN KEY SWITCH ON.
OPEN CABINET DOOR TO TEST.

