

Response[™]

Dummy Internal Dome Camera CA9



Installation Instructions

These instructions should be retained in a safe place for future reference.

The Response Dummy Wired Internal Dome Camera is a non functioning unit, although it is identical in appearance to the Response Wired Internal Dome Camera (CA8). It is intended for use as a visual deterrent to assist in the protection of your home or office, etc. The dummy dome camera is easily mounted on the ceiling using the cameras mounting base.

Please read before you start:

Always use discretion when installing CCTV surveillance equipment especially when there is perceived policy. Enquire regarding local regulations applicable to the lawful installation of video recording/surveillance. Third party consent may be required.

SAFETY AND INSTALLATION TIPS:

When installing any CCTV camera(s), always follow manufacturer's advice when using power tools, steps, ladders, etc. and wear suitable protective equipment (e.g. safety goggles) when drilling holes. Before drilling holes through a ceiling check for hidden electricity cables and water pipes. The use of a cable/pipe detector is advisable.

KIT CONTENTS

- 1 x Dummy Dome Camera
- 1 x Camera fixings kit - ceiling plugs and screws
 - For the dome cameras mounting base - 4 x Ø3.5mm x 19mm screws*
 - and 4 x No.7, 29mm ceiling plugs*
- 1 x Installation manual
- 1 x Window sticker

Tools Required:

- Electric drill
- 5mm masonry drill bit
- No. 2 Philips screwdriver
- 3mm flat blade screwdriver

1. Unscrew the rim part of the dome cover from its base as shown (Fig. 1).

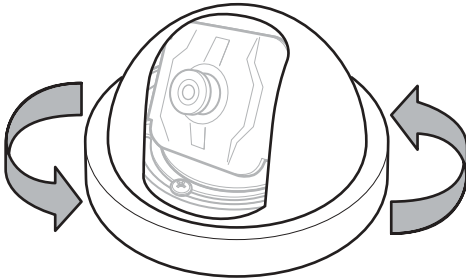

Fig. 1.

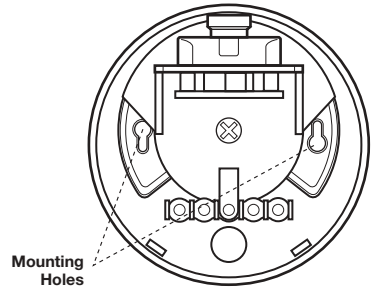

Fig. 2.

2. Use the base of the camera to mark out the key hole mounting holes (Fig. 2).
3. Mount the base to the ceiling using the supplied fixing screws and plugs. Adjust the tilt and panning positions of the camera lens as shown (Fig. 3).

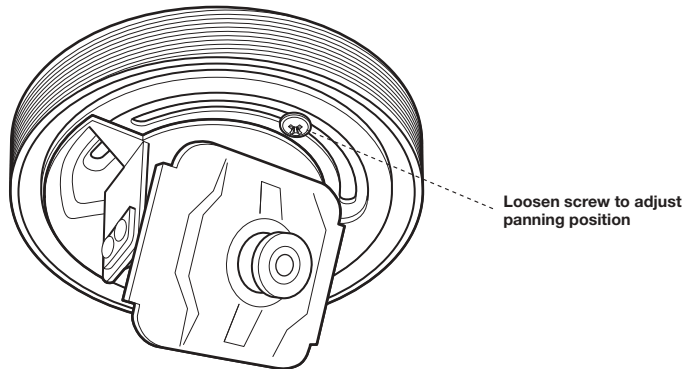

Fig. 3.

Refit the cover of the camera on to its base.

There are a range of accessories available in the Response CCTV product range to expand your system:

- CWK1** **Wired Colour Camera CCTV Kit**
- CA1** **2 Channel Digital Video Image Recorder**
- CA2** **LCD Screen for Wireless/Wired CCTV Kits**
- CWFK1** **Wireless Colour Camera CCTV Kit**
- CA3** **Wireless Colour Accessory Camera**
(requires CWFK1 CCTV KIT to operate)
- CA5** **Professional Heavy Duty Camera CCTV Kit**
- CA6** **Dummy Professional Heavy Duty Camera**
- CA7** **4 Channel Digital Video Image Recorder**
- CA8** **Wired Internal Colour Dome Camera CCTV Kit**
- CA10** **Heavy Duty Colour Camera CCTV Kit**
- CA11** **Dummy Heavy Duty Camera**
- CA4** **10m Extension Cable Kit**
- CA12** **20m Extension Cable Kit**

Directive (2002/96/EC)

This product is classified by the Waste Electrical or Electronic Equipment (WEEE) Directive. It should not be disposed of with other household or commercial waste. At the end of its useful life the packaging and product should be disposed of via a suitable recycling centre. For information on available facilities, please contact your local authority or the retailer from where the product was purchased.



Novar ED&S undertakes to replace or repair at its discretion goods (excluding non rechargeable batteries) should they become defective within 1 year solely as a result of faulty materials and workmanship.

If the product has not been installed, operated or maintained in accordance with the instructions, has not been used appropriately or if any attempt has been made to rectify, dismantle or alter the product in any way the guarantee will be invalidated.

The guarantee states Novar ED&S entire liability. It does not extend to cover consequential loss or damage or installation costs arising from the defective product. This guarantee does not in any way affect the statutory or other rights of a consumer and applies to products installed within UK and Eire only.

If an item develops a fault, the product must be returned to the point of sale with:

1. Proof of purchase.
2. A full description of the fault.
3. All relevant batteries (disconnected).

Response is a trademark of Novar ED&S.

CUSTOMER HELPLINE

Most issues can be solved over the phone in a few minutes.

Please contact our Helpline Team on the number below for any installation and general advice regarding our products:

0844 736 9149

Lines open 9.00am to 5.00pm, Monday to Friday.

Calls charged at service providers national rate.



Novar Electrical Devices and Systems Limited. (A Honeywell Company)

The Arnold Centre, Paycocke Road, Basildon, Essex SS14 3EA. UK

www.friedland.co.uk