

CAM940C/CAM940CE

Passive Infrared Detector with High Resolution Color Video Output Installation Instructions

1.0 Description

The CAM940C (standard composite NTSC format) and the CAM940CE (PAL format) provide high resolution, fixed-focus, CCD color cameras and high performance PIR motion sensors using advanced signal processing to provide outstanding catch performance and unsurpassed false alarm immunity. Their Passive Infrared (PIR) motion sensors are designed to detect movement in the interior of a structure by sensing the Infrared energy emitted from the human body as it moves across the sensor's field of view. When motion is detected, the Detector sends an alarm signal to the Control Panel with a form "A" (NC) set of contacts. An auxiliary form "C" (NC, C, NO) contact set is available for turning on auxiliary devices, such as VCRs.

2.0 Specifications

- **Input Power:** 10-14 volts DC
- **Current Draw:** 35 mA @ 12 VDC Standby, 150 mA in Alarm or with camera on
- **Standby Power:** No internal standby battery. Connect to DC power source capable of supplying standby power. *Four hours (140 mAh) are required for UL Listed installations.*
- **PIR Coverage:** 40 x 40 feet (12 x 12 meters)
- **Relays:** One form "A" Normally Closed (NC) contact set and one form "C" (NC, C, NO) contact set rated for 125 mA @ 12 volts maximum DC or AC for resistive loads.
- **Temperature:** +14°F to +120°F (-10°C to +49°C). *For UL Listed Installations, the temperature range is +32°F to +120°F (0°C to +49°C).*
- **Humidity:** 0 - 85% non-condensing.

- **Dimensions (HxWxD):** 3.75 in. x 2.25 in. x 1.5 in. (9.5 cm x 5.7 cm x 3.8 cm)
- **Mounting:** B335 Swivel Bracket (included); B338 Ceiling Bracket (optional).

Camera Specifications:

- **S/N Ratio:** >46 dB
- **Sensitivity:** 3.4 Lux
- **Scanning System:** 2:1 interlaced
- **Video Signal:** CAM940C: NTSC 75 Ω
CAM940CE: PAL 75 Ω
- **Field of View:** 75°
- **Horizontal Resolution:** 330 lines
- **Effective Pixels:** CAM940C: 512 (H) x 492 (V)
CAM940CE: 512 (H) x 582 (V)
- **Image Device:** 1/3-inch color CCD
- **Electronic Shutter:** 1/60-1/100,000 second
- **Lens:** 3.6 mm fixed focal length

3.0 Installation

- 3.1 Remove the cover** using a small flat-blade screwdriver.

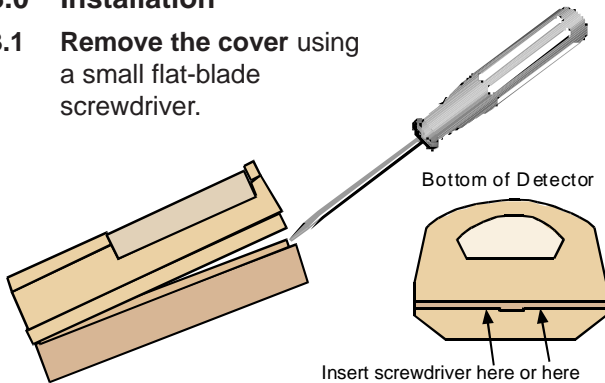

- 3.2 Press the latching tab** toward the side of the case and lift out the board.

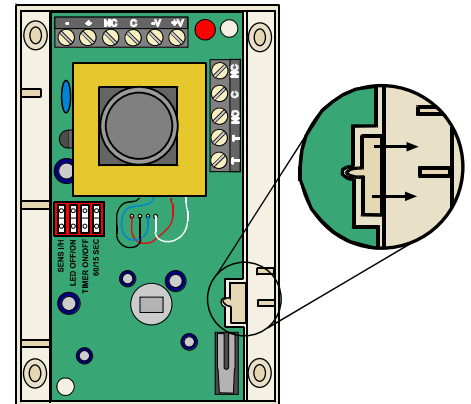

- 3.3 Select a mounting location**

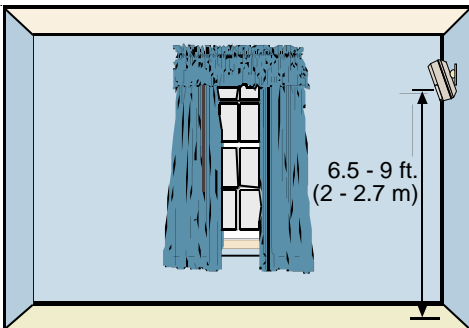

Mount the detector 6.5 - 9 ft. (2 - 2.7 m) above the floor.

- 3.4 Avoid:**

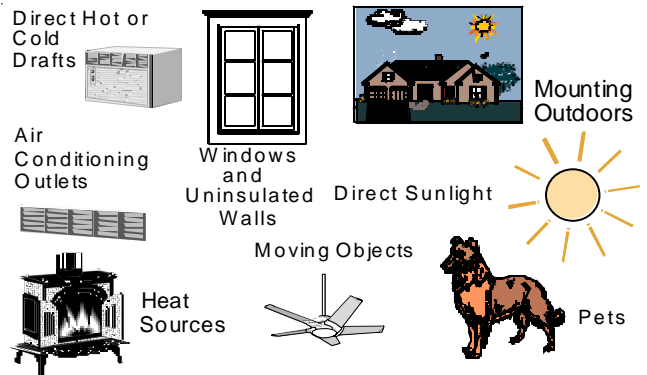

3.5 Mount the detector

A. Remove

Areas to mount the B335 Bracket

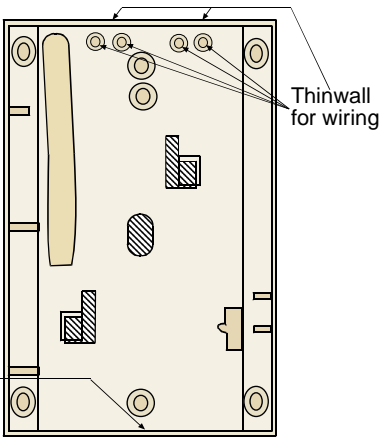

B. Attach the Adapter Plate to the back of the base.

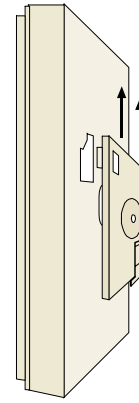
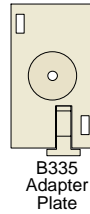

C. Attach the B335 (1) to the wall and attach the base (2) to the B335.

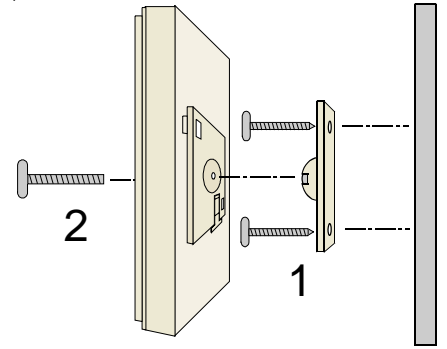

Note: To avoid possible circuit board damage, use **only** the mounting hardware provided.

3.6 Wire the Detector

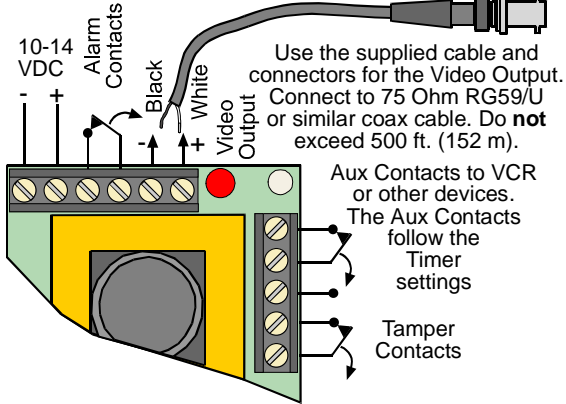

3.7 Set the switches

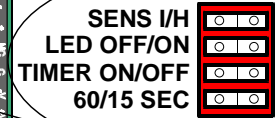
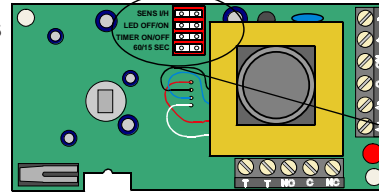

SENS: OFF = Intermediate Sensitivity. **ON** = High Sensitivity.
LED: OFF = No LED. **ON** = LED on for alarms.
TIMER: OFF = Camera on all the time. **ON** = Camera follows the 60/15 SEC timer.
60/15 SEC: If the **TIMER** switch is set to **ON**, the camera and Aux contacts will be on for a minimum of 60 seconds if the 60/15 switch is set to **OFF**. The camera/Aux contacts will be on for a minimum of 15 seconds if the 60/15 switch is set to **ON**. Any new motion will restart the timer and the camera/ Aux contacts will remain on.

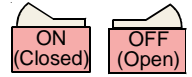

4.0 Align the Detector

with the camera on and the cover in place. The camera "sees" a higher area than the PIR detector. Mounting the detector flat on the wall or pointing the detector too low will result in poor catch performance. Use the supplied bracket.

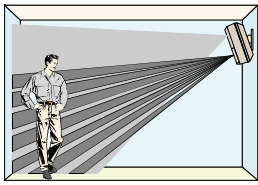

OK

Camera View
PIR Pattern

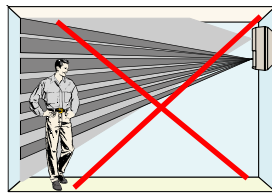

NO

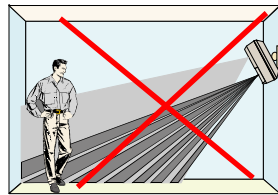

NO

5.0 Walk Test the detector.

Perform this test at the time of installation and monthly thereafter.

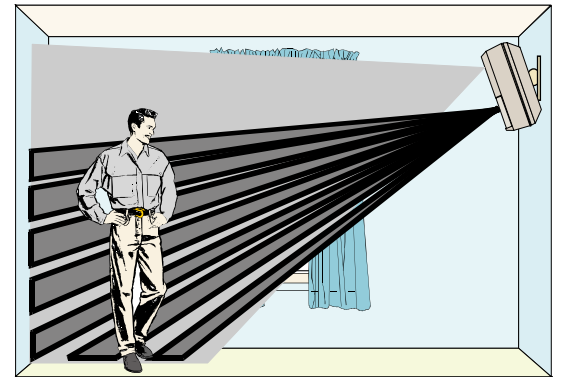

6.0 Coverage Patterns

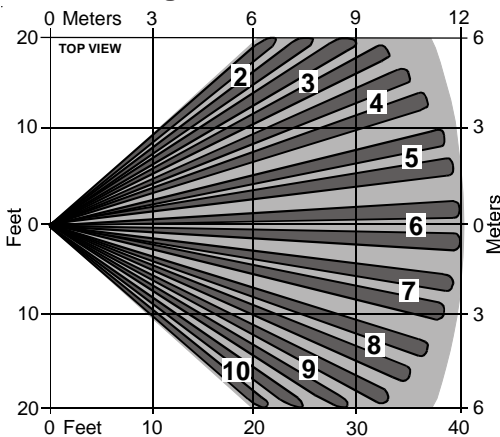

Although generally not required, if masking is desired the lens diagram shows the appropriate areas to be masked. Use an opaque material (such as electrical tape) to mask the desired areas.

PIR
Camera

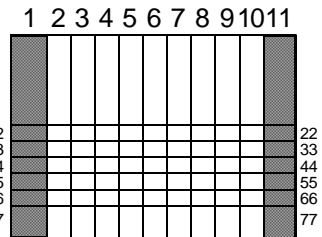
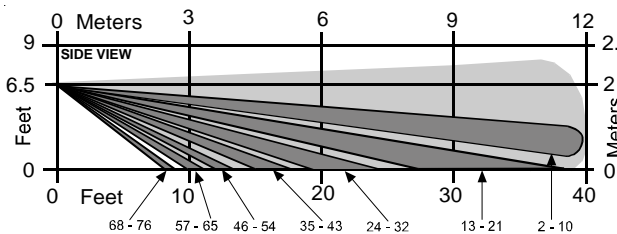

CAM940C Lens (inside view)

Areas not used

