

# INSTALLATION INSTRUCTIONS

## DS415i Photoelectric Intrusion Detection System

### OPTIONAL ACCESSORIES



**AL402**  
Alignment Light



**TC6000**  
Test Cord

### SUMMARY GUIDELINES

- |                                      |               |
|--------------------------------------|---------------|
| <b>A.) General Information</b>       | <b>Page 2</b> |
| <b>B.) Mounting</b>                  | <b>Page 2</b> |
| <b>C.) Wiring</b>                    | <b>Page 2</b> |
| Receiver Wiring                      |               |
| Transmitter Wiring                   |               |
| Retransmission Wiring                |               |
| <b>D.) Alignment</b>                 | <b>Page 3</b> |
| Transmitter Alignment                |               |
| Receiver Alignment                   |               |
| Fine Peak Alignment                  |               |
| <b>E.) Set-Up and Walk Testing</b>   | <b>Page 4</b> |
| Battery Connection/Testing           |               |
| Alarm Retransmission Circuit Testing |               |
| Margin Test Switch                   |               |
| <b>F.) Other Information</b>         | <b>Page 4</b> |
| Maintenance                          |               |
| Testing                              |               |

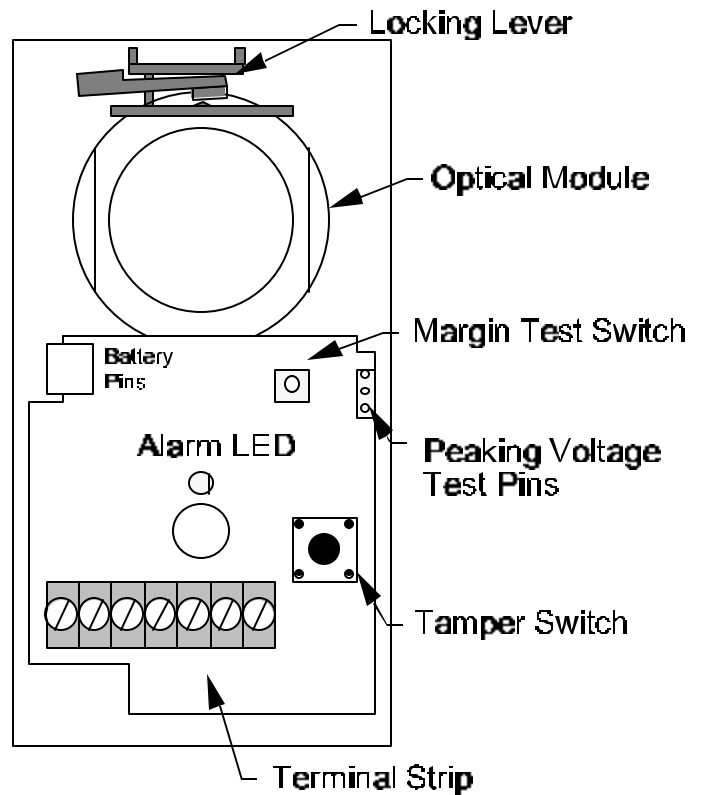

**Front View of Receiver  
with Cover Off**

## A.) GENERAL INFORMATION:

### Description:

The DS415i is a pulsed active infrared photoelectric intrusion detection system designed to provide an alarm activation upon the detection of an intruder passing through its beam. It consists of a separate Transmitter and Receiver and is capable of coverage ranges up to 500 feet (150m).

The Transmitter emits an invisible, pulsed infrared beam which is received by the Receiver. If an intruder passes between the Transmitter and Receiver, causing a beam blockage for a minimum of 55ms, the Receiver will indicate an alarm.

The DS415i receiver and transmitter are intended to be mounted indoors only.

### Specifications:

Input Power: 8 to 14.5 VDC or 12 VAC.  
*For DC input applications connect the unit only to a U.L. listed power supply or control unit capable of providing at least 4 hours of standby time. For U.L. certified, AC input applications the TR12 transformer and P333 battery pack shall be used.*

Current Draw: Transmitter - 8mA @ 12 VDC.  
 68 mA RMS with battery.  
 Receiver - 33 mA @ 12 VDC.  
 95 mA RMS with battery

Range: 500 feet (150 meters).

Alarm Output: Form "C" Rated at 125mA @28VDC.

Tamper Output: Normally Closed Rated at 125mA @28VDC.

Temperature: Storage and operating temperature range is 0°F to +120°F (-18°C to + 49°C).  
*For UL installations the operating range is +32°F +120°F (0°C to 49°C).*

Optional Accessories: TR12 Transformer, AL402 Alignment Light, P333 Standby Battery, TC6000 Test Cord, AE405 Splash Resistant Enclosure, M402A Mirror. *The AE405 and M402A shall not be used in U.L. certificated installations.*

### B.) MOUNTING:

( ) Choose a location where an intruder entering the area will have to cross between the Transmitter and the Receiver.

( ) Mounting surface should be rigid, and selected as to offer a clear line of sight between the Transmitter and Receiver.

( ) Remove the cover of the Transmitter and, using the back of the chassis as a template, locate and mark the four keyed mounting slots on the mounting surface.

( ) Prestart the mounting screws in the mounting surface, attach and secure the chassis to the mounting surface.

( ) Repeat the mounting procedure using the Receiver.

### C.) WIRING:

( ) Wire the Transmitter and Receiver as shown.

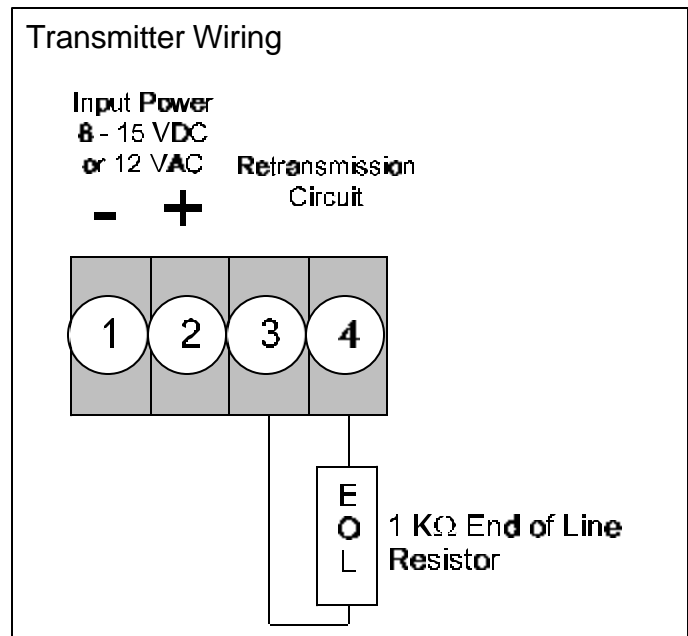
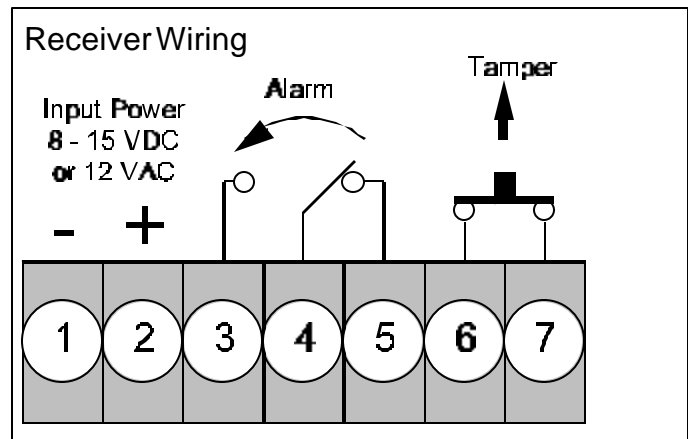

### Alarm Retransmission Circuit Information:

The Transmitter allows connection of normally open or normally closed contacts to a supervised alarm retransmission circuit.

continues...

Alarm retransmission allows dry contact devices such as door or window contacts to be wired into the Transmitter using it as a relay path to the Receiver without additional wiring to the Control Panel.

**Retransmission Wiring:**

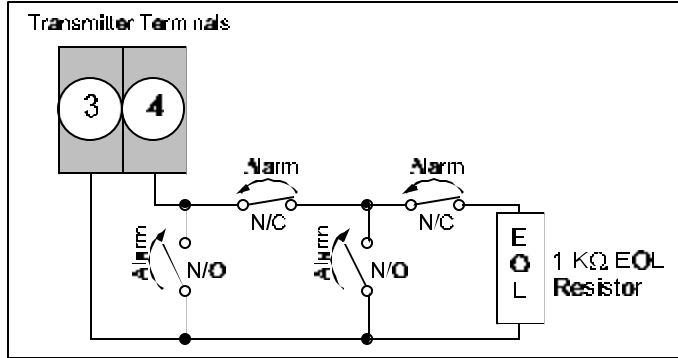

**D.) ALIGNMENT:**

Note: The use of an AL402 Alignment Light is suggested in the alignment of this detector.

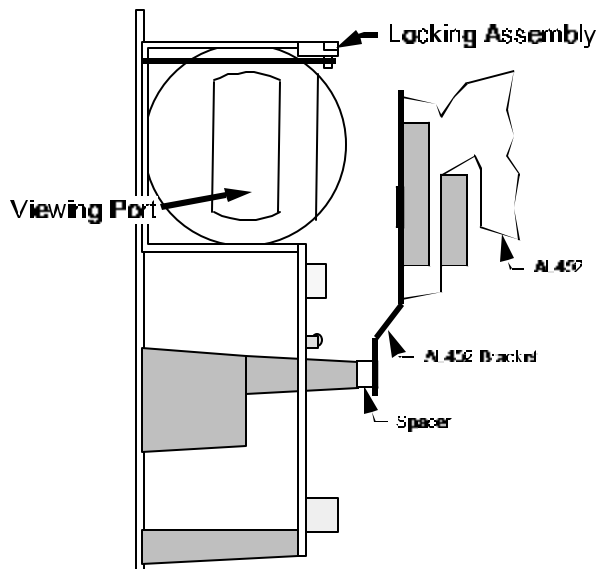

**Transmitter Alignment:**

- ( ) Mount the AL402 Alignment Light to the Receiver and connect the two AL402 leads to the spade lugs on the receiver power terminals (1 and 2).
- ( ) Adjust the AL402 until the flashing light falls directly on the Transmitter. Lock the AL402 into place.

( ) At the Transmitter, unlock the optical module by swinging the locking lever forward. Look through the viewing port on the side of the optical module and align the optical module until the flashing light from the AL402 falls completely through the hole in the white image plane.

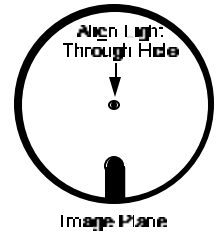

- ( ) Lock the optical module in place by returning the locking lever to its original position.
- ( ) Insert the module seal if extra bug and dust immunity is desired.

**Receiver Alignment:**

( ) Remove the AL402 from the Receiver and mount it on the Transmitter. Connect the two AL402 leads to the Transmitter power terminals (1 and 2).

( ) Adjust the AL402 until the flashing light falls directly on the Receiver.

( ) At the Receiver, unlock the optical module by swinging the locking lever forward. Align the optical module until the flashing light from the AL402 falls completely through the hole in the white image plane.

( ) Remove the AL402 from the Transmitter.

**Fine Peak Alignment:**

( ) Fine peak the Receiver alignment by connecting a VOM on its lowest DC voltage scale to the Peaking Voltage Tests points on the Receiver using a TC6000 Test Cord.

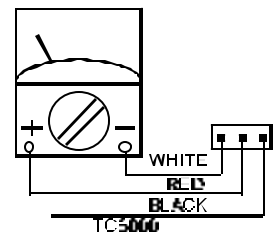

( ) Adjust the Receiver's optical module until the highest voltage is shown on the meter.

( ) Lock the optical module in place and remove the meter.

( ) Insert the module seals if desired.

### Margin Test Switch:

The Margin Test Switch on the Receiver helps insure that the detector is aligned properly by decreasing the signal into the Receiver when pressed.

( ) Press and hold the Margin Test Switch. Be careful not to block the beam when pressing the switch.

The Alarm LED should remain OFF while pressing the Margin Test Switch. If the LED goes ON, the alignment is insufficient and the detector should be realigned.

### E.) SET-UP AND WALK TESTING:

( ) Place the covers on both units.

( ) Walk test the system by passing between the Transmitter and Receiver at several points in the coverage area. Take care to ensure that the beam is parallel to the floor and not reflecting off of polished floors or walls.

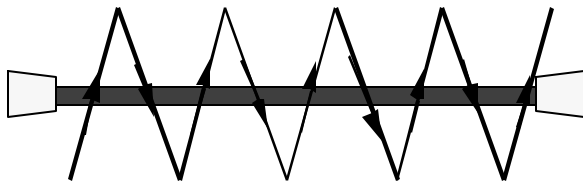

**Note:** The infrared beam may be reflected off of shiny objects, walls, or floors. **It is extremely important to walk test the system at all points that coverage is expected.**

### Battery Connection/Testing:

**Note:** The battery is for AC Units Only. Do not install the battery on DC powered units.

The P333 Battery is supplied as backup power when the unit will be powered from a transformer.

( ) Plug the battery connector into the battery pins on the unit.

( ) Unplug the AC Transformer at the Transmitter and observe the Receiver's Alarm LED.

The Receiver's Alarm LED should remain OFF.

( ) Walk test the units by walking between the Transmitter and Receiver. Insure that the Receiver's alarm LED lights when the beam is blocked.

( ) Unplug the Receiver's Transformer and repeat the walk test.

( ) Plug both Transformers back in.

### Alarm Retransmission Circuit Testing:

If the retransmission circuit is used,

( ) Activate the devices connected to the retransmission circuit and observe the Receiver's alarm LED.

The Receiver's alarm LED should light and the alarm relay should transfer when devices connected to the retransmission circuit are activated.

### Margin Test Switch:

The Margin Test Switch on the Receiver helps insure that the detector is aligned properly by decreasing the signal into the Receiver when pressed.

( ) Press and hold the Margin Test Switch. Be careful not to block the beam when pressing the switch.

### F.) OTHER INFORMATION:

#### Maintenance:

At least once per year, the front covers of both units should be cleaned using a commonly available window cleaner, and a soft, dry cloth.

#### Testing:

The end user should be instructed on the proper test procedures and frequency.

The only way to insure continued daily operation of any intrusion detection system is to perform regular walk tests of the coverage area.