

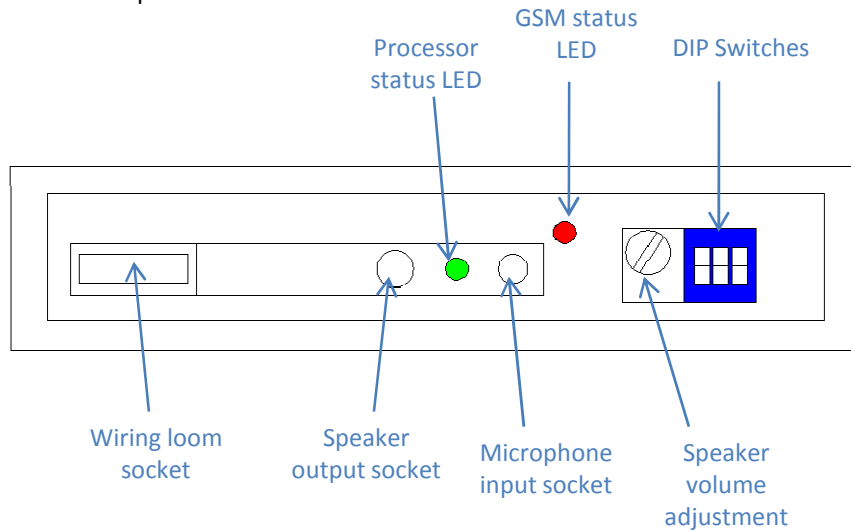

- 1) Please read this entire manual before attempting to install this system.
- 2) Always ensure that the power is switched OFF before inserting or removing a SIM card.
- 3) When mounting the intercom, position the call point as close to head height as possible (1600mm from ground level).
- 4) To minimise GSM Rf interference on the call, position the GSM unit as far away from the call point as possible, and install the GSM antenna away from both mentioned items in a prominent elevated position if possible.
- 5) The GSM unit requires mounting in a weatherproof enclosure for out door operation.

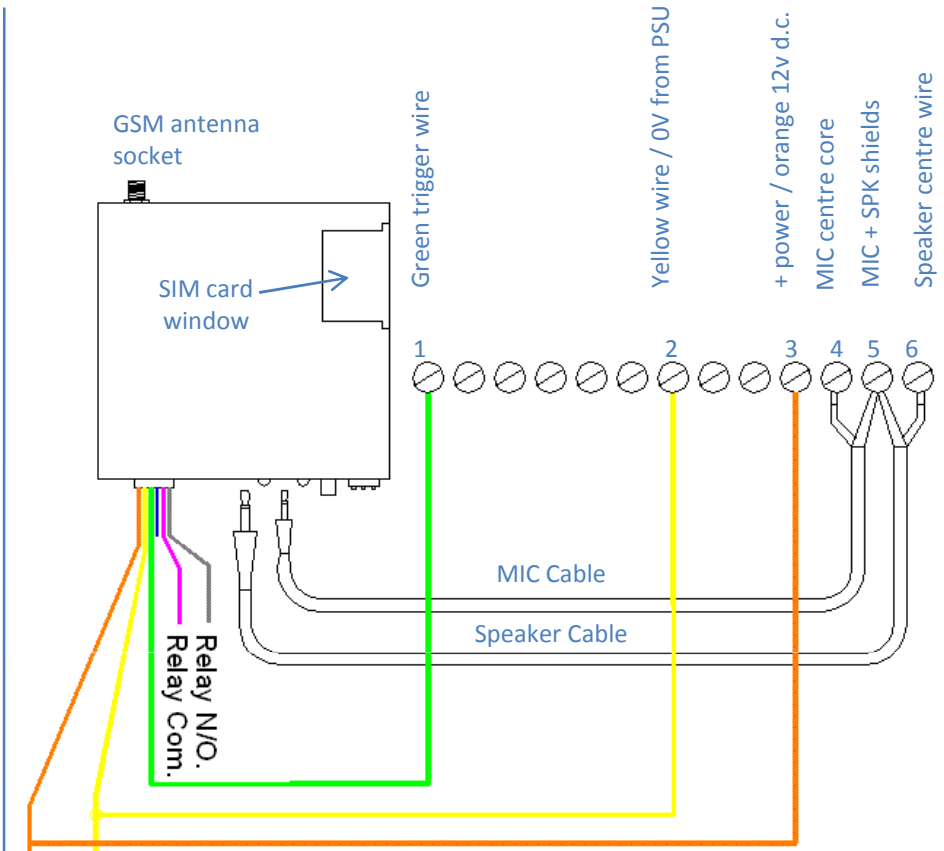

Switch	Application	ON	OFF
1	Programming mode	Enabled	Disabled
2	Automatic number learning or manual number entering	Automatic	Manual
3	Relay output function (Usually off for automatic gates)	Latching	Pulse



+12V d.c. (orange)
Ground / 0V (yellow)

Terminal	Description
1	Trigger input
2	GND / 0V
3	+12v d.c. power
4	MIC centre wire
5	SPK + MIC Shielding
6	Speaker centre wire



SIM Card

Choose a SIM card which has the best reception in the area. Poorer reception areas will cause the GSM unit to boost its Rf output power, which will increase the amount of GSM hum or interference which can be heard on the call.

If you are using a pay and go SIM card, please ensure that the unit has adequate calling credit before installing into the unit. Please also ensure that there are no ring back features enabled or call divert.

Telephone Number Memory Locations

The following table describes the functions of memory locations in the unit.

Location	Function / Description
000	Master programmer location. Any number stored here will be able to reprogram the unit without needing to attend the site and switch on DIP switch 1.
001	First telephone number which the intercom will call when a visitor presses the call button.
002	Second number which will only be called if there is no answer at the first.
003	Third number which will only be called if there is no answer at the first or second.
004 - 999	Numbers stored in these locations can call the unit to gain access at no call charge. I.e. Call your gate / door to open. The unit will recognise the number, trigger the output relay, and hang up without answering the call.

Programming

- 1) To begin programming, ensure that DIP1 is ON, enabling programming mode. and DIP 2 is ON enabling manual programming mode (most popular method).
- 2) Ring the unit from the master telephone number which you intend to use for maintenance etc. Once the GSM unit answers, you will hear a long acknowledgment tone.
- 3) Enter the following sequence to clear the SIM card from all data and numbers...



- 4) The unit will now hang up. Redial the intercom number to recommence programming.
- 5) Enter the following sequence to program in the master telephone number...

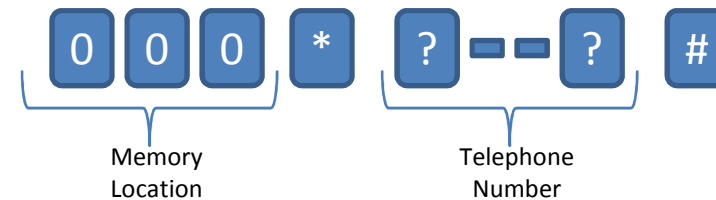

After entering each number, the unit will play an audible message, repeating the number back to you.

- 6) Repeat this process for memory location 1, entering the number you want the intercom to dial when a visitor arrives, and if required, repeat for locations 2 and 3.

As described in table 3, locations 4 to 999 can be used to store numbers which can ring the intercom to gain access at no call charge.

- 7) When finished, PLEASE ENSURE TO SWITCH OFF DIP SWITCH 1, SO THAT THE UNIT WILL RETURN TO NORMAL OPERATION MODE BEFORE TESTING. Once the master number has been entered, the master number can ring the unit and change programming at any time, even with DIP switch 1 OFF.



Testing

- 1) After programming is complete, press the call button. The speaker will announce “please wait, your call will be answered shortly”. The unit will then dial the first number in the calling list.
- 2) Answer the call and check that 2 way audio is present. Note, if echo is experienced on the call, reduce the volume control on the GSM unit. Most loudspeaker GSM audio systems experience some GSM hum. If there is excessive hum, try changing the SIM card to another network provider who may have a mast located closer to the site.

Additional Features

- 1) When the master user calls the SIM in the GSM unit, it will answer the call to allow access to programming features. Sometimes it is necessary for the master user to trigger the relay output. This can be done by entering the following sequence....



Trouble Shooting

- 1) The GSM unit will not boot up. **A – Check power source is correct and polarity is good.**
- 2) The GSM unit will not answer my call. **A – Check SIM card is installed correctly. Check the SIM card can be called when installed in a mobile phone. If not, it may need registered and credit applied. If the SIM card functions normally, check the DIP switch 1 is ON for programming mode. Note: Phones that with hold their number cannot call the unit either for programming or to open gates etc.**
- 3) The unit can be programmed normally, but the call button does not work. **A – Check the power source is d.c. Check wiring.**
- 4) The unit works and programs OK but does not work in a specific location or site. **A – Check the reception of the SIM card in a mobile phone at the customer’s site.**

Contact Information

For technical support, contact your distributor or supplier firstly.

Manufactured by;
Advanced Electronic Solutions
Unit A,
4 Annagh Road,
Cookstown,
Co Tyrone,
BT80 8WH
Northern Ireland

Tel: 0044 (0)28 8676 7878

Fax: 0044 (0)28 8676 0085

www.AES-NI.co.uk