

**DETECTOR
TRANSMITTER**
Cat No. TLTX2000B



**INSTALLATION & OPERATING
INSTRUCTIONS**

Introduction

The TLTX2000B Controller Transmitter is part of the Timeguard range of PIR products which communicate by radio frequency (r.f.) signals. This enables substantial amounts of wiring to be eliminated which is particularly useful in long wiring runs and coverage of outbuildings.

It is a combined PIR detector, controller and r.f. transmitter. It detects moving body heat and turns lighting on and transmits (sends) a signal to receivers in the system that have been programmed to respond to its coded signal causing their lights to turn on.

In the following instructions products with catalogue numbers including TX (ones that send information about PIR detection) are referred to as Tx units and products with catalogue numbers including RX (ones that receive information about PIR detection) are referred to as Rx units.

1

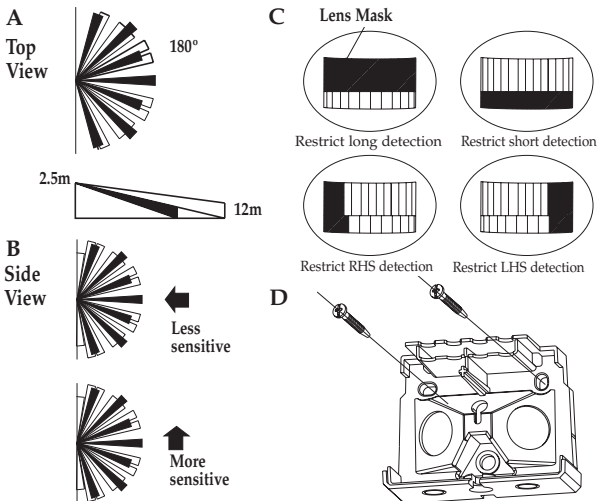

Parts included

- PIR controller transmitter unit.
- Instruction manual. Please keep safe for future reference.
- Accessory Pack.

Tools and parts needed

- Electric/hand-held drill & bits.
- Terminal or Electricians screwdriver
- Large slotted/philips screwdriver
- Wire cutters

Unit is for outdoor use only.

If in any doubt, consult a qualified electrician.

Selecting a location

For optimum performance, mount the Tx unit at 2.5m (8ft) high. The sensor can be pointed in any direction as long as it is within 100m of the receivers it is to be used with. The sensor can detect motion up to 12m within a 180 degree radius.

Avoid areas where pets or traffic may trigger the sensor.

Avoid mounting where the Sensor aims at objects that change temperature rapidly, such as central heating vents, air conditioners or waving branches. Avoid reflective surfaces like conservatories or pools of water.

The detector moves up or down, left or right to change the coverage area.

Keep in mind the sensor is most sensitive to movement across its field of vision.

The motion detector has a number of detection zones, at various vertical and horizontal angles as shown (see diagram A). A moving human body needs to cross/enter one of these zones to activate the detector. The best all-round coverage is achieved with the unit mounted at the optimum height of 2.5m. Careful positioning of the detector will be required to ensure optimum performance. See diagram A detailing detection range and direction.

The detector is more sensitive to movement ACROSS its field of vision than to movement directly TOWARDS it (see diagram B). Therefore position the unit so that the sensor looks ACROSS the likely approach path.

Avoid positioning the unit where there are any sources of heat in the detection area (extractor fans, tumble dryer exhausts etc.).

Reflective surfaces (ie pools of water or white-painted walls) and overhanging branches may cause false activation under extreme conditions.

During extreme weather conditions the motion sensor may exhibit unusual behaviour. This does not indicate a fault with the sensor. Once normal weather conditions return, the sensor will resume normal operation.

When siting Rx units that will need to work with the TLTX2000B the signal reception range will be less than 100m if walls or chain link fences come between the Tx and Rx units - if there is any doubt whether communication will take place make temporary installations before programming.

Installation

IMPORTANT

Switch off the electricity at the fuse box by removing the relevant fuse or switching off the circuit breaker before proceeding with the installation.

Release screw on underside of unit and remove wall plate from main body of sensor, this screw is captive, do not remove. (Fig G)

Mark position of the fixing holes. (Fig D)

Drill the holes. Insert the wall plugs into the holes.

Pass the cable through the wall bracket before securing wall bracket to the wall.

Pierce the grommet and pass the cable through the wall bracket. Allow approximately 100mm of cable to pass through the grommet. (A template for this wire length

is provided on page 10 of this manual).

Fit grommet into its location hole ensuring a good seal. Fix the mounting plate to the wall. Take care not to overtighten the screws to prevent damage to the mounting plate. If using a power screwdriver, use the lowest torque setting.

Connection

This unit is supplied with a hanging attachment (tether) to aid installation. If it is not required remove from the unit and discard.

Place the round end of the tether into the keyhole location on the wall bracket. ensure the tether is securely located in the slot before releasing the weight of the unit.

Connect the mains supply cable to the terminal block on the unit as follows (see connection diagram):

NEUTRAL (Blue) N

EARTH (Green/Yellow) 

LIVE (Brown) L

Connect the cable from the lighting load to the terminal block on the unit as follows (see connection diagram):

NEUTRAL (Blue) N

EARTH (Green/Yellow) 

LIVE (Brown) L1

Ensure that all connections are secure.

Ensure the connectors are secure.

Place terminal block onto its securing pillar on the wall bracket. (Fig E)

Fit PIR to wall bracket and secure by fixing screw. (Fig G)

Connection Diagram

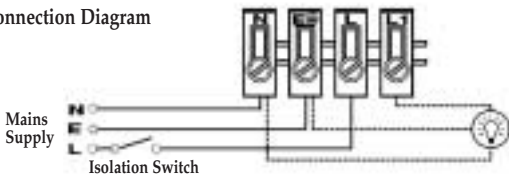

Setting up

The sensor will rotate from left to right, and tilt forward or backward. Adjust the sensor to point in the required direction. (note diagram B)

The unit can be set up in daylight or at night.

Set the DUSK control to "Sun" position and the TIME setting to minimum.

Turn the power to the unit on. The lamp(s) under control will illuminate for approximately 30 seconds. This indicates the unit is wired correctly.

The unit is now in Test Mode. The LEDs will scroll from left to right, and "blink" on and off very fast on detection of movement and transmission to the Rx unit.

If the detection area is too small for your requirements, try angling the sensor head up.

Angling the head downwards will reduce the detection area should a smaller range be required.

The TIME control determines how long the unit remains illuminated following activation and after all motion ceases.

(See diagram F, the time adjustment knob is indicated by the "Clock" symbol).

The minimum time (fully anti-clockwise) is approx. 5 seconds, whilst the maximum time (fully clockwise) is approx. 5 minutes. Set the control to the desired setting between these limits.

The DUSK control determines the level of darkness required for the unit to start operating. The setting is best achieved by the procedure below:

(See diagram G, the Dusk adjustment knob is indicated by the "Moon" and "Sun" symbols).

Set the DUSK control knob fully anti clockwise. Wait until darkness falls.

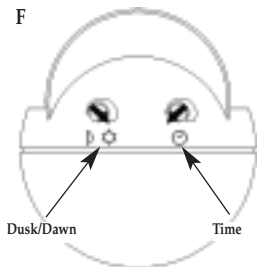
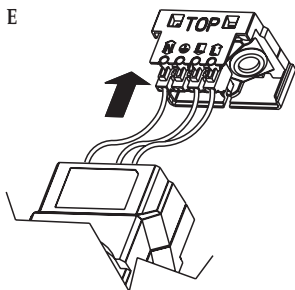

When the ambient light level reaches the level of darkness at which you wish the lamp to become operative (i.e.: at dusk) SLOWLY rotate the control in a clockwise direction while slowly moving a hand backwards and forwards in front of the detector. Do this until the lamp(s) under control illuminate. Leave the control set at this point.

At this position the unit should become operative at approximately the same level of darkness each evening. Observe the operation of the unit. If the unit is starting to operate too early (i.e.: when it is quite light) adjust the control slightly anti-clockwise. If the unit starts to operate too late (i.e.: when it is very dark) adjust the control slightly clockwise.

The LED's will scroll from left to right, day and night; indicating the unit is in Detection Mode.

The LED's will extinguish when the PIR activates the light for as long as the lamp is illuminated.

Masking the Sensor Lens

To restrict the sensor coverage, preventing detection in unwanted areas, mask the sensor lens using the masks provided in the accessory pack (see diagram C). For your information, the top section of the lens covers long range detection, the bottom covers short range. Similarly the left and right lens sections cover the left and right detection areas respectively.

Manual Override Mode - Single LED Illuminated

The light can be switched on for longer time periods by use of the Manual Override Mode. This can be activated at night by using the internal wall switch or circuit breaker.

Switch the internal wall switch/circuit breaker once (off/on) within 2 seconds. The unit will now illuminate continuously it is switched back into Detection Mode.

7 Programming

To be operated by the Timeguard Wireless Transmitters, the Timeguard Wireless Receivers must learn the Transmitters unique code. This programming is achieved automatically by the following procedure.

1. Press the Rx unit's PROGRAM button for 1 to 2 seconds while the Rx unit is powered. Be careful not to press for much longer than 2 seconds or you may erase all existing memorised codes. The light will go ON indicating it is in PROGRAM MODE and will remain on for up to 5 minutes. (If programming a Chime Receiver it will make a "beep" and the LED will flash indicating it is Program Mode).
2. Activate the Tx unit's detector to send a signal to the Rx unit by walking into its detection zone. The TLTX2000B turns its connected lighting on and its LED flashes red indicating motion has been detected and a

signal has been transmitted. The Tx unit will send its coded signal to the Rx unit and its light will go off. (if using a Chime receiver a “beep” will sound indicating it has been coded with the Tx units signal).

3. The Rx unit has acknowledged the Tx unit signal by turning the lights OFF. The Rx unit is now programmed to respond to the Tx unit. No other Tx unit can activate this RX unit unless it is programmed to do so.

4. If the lights did not go OFF or the Chime did not “beep” the Rx unit is not picking up a signal. Check the radio signal path between the Sensor and Receiver for any metal obstructions (walls, support beams, chain link fences etc). These can block radio signals and interfere with signal transmission.

5. Further Rx units may now be introduced to the Tx unit if required.

PLEASE NOTE:- PLEASE SEE THE SEPARATE INSTRUCTION MANUALS FOR THE RECEIVER PRODUCTS TO UNDERSTAND HOW TO PROGRAM AND ADJUST THAT SPECIFIC Rx UNIT.

Technical specifications

Detection Range:	Up to 12 metres
Detection Angle:	180°
Power Supply:	230 V AC ~ 50Hz
Maximum Switchable Load:	2000W (4 x 500W Tungsten Halogen)
Time On Adjustment:	5 seconds - 5 minutes
Dusk Level Adjustment:	Day & night or night only operation
Environmental Protection:	IP44 (suitable for outdoor use)
Transmission Range:	Up to 100m (varies with surrounding structures)
Conforms to Directives:	72/23/EEC and 89/336/EEC

Troubleshooting guide

Problem

- Lamp stays ON all the time at night.

Solution

The unit may be suffering from false activation. Cover the sensor lens completely with a thick cloth. This will prevent the sensor from "seeing" anything. If the unit now switches off after the set time duration and does not re-activate, this indicates that the problem was caused by false activation. The problem may be solved by slightly adjusting the direction/ angle of the sensor head (see Setting Up).

- PIR keeps activating for no reason/at random.

You may not be allowing the unit time to complete its warm-up period. Stand well out of the detection range and wait (the warm-up period should never exceed 1/2 minutes).

Occasionally, winds may activate the sensor. Sometimes passages between buildings etc. can cause a "wind tunnel" effect.

Ensure the unit is not positioned so as to allow detection of cars/people using public thoroughfares adjacent to your property.

- PIR sensor will not operate at all.

Check that the power is switched ON at the isolation switch.

Turn OFF the power to the unit and check the wiring connections as per the diagram (see Installation). Ensure no connections are loose.

Check the lamp. If the lamp has failed, replace. Ensure that the lamp is seated correctly in the lampholder.

- The PIR sensor will not operate at night.

The level of ambient light in the area may be too bright to allow operation at the current DUSK setting. During the hours of darkness, adjust the DUSK control slowly clockwise until the lamp illuminates. Refer to Setting Up for more details.

- Unit activates during the daytime.

The level of ambient light in the area may be too dark for the current DUSK setting. During daylight, adjust the DUSK control slightly anti-clockwise. When the lamp load extinguishes, enter the detection area. If the PIR still activates, the setting is still too high. Repeat the above procedure until the PIR does not activate when you enter the detection area. Refer to Setting Up for more details.

- PIR coverage is poor/sporadic

Unit may be poorly located. See Selecting a Location and re-locate the unit.

- Detection range varies from day to day

PIR sensors are influenced by climatic conditions. The colder the ambient temperature, the more effective the sensor will be. You may need to make seasonal adjustments to the sensor head position to ensure trouble-free operation all year round.

Incoming Wire Template

Use this template to estimate incoming cable length

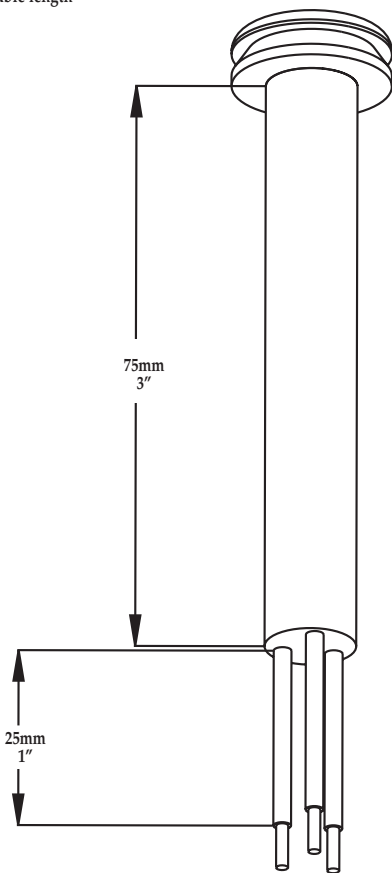

5 Year Guarantee

In the unlikely event of this product becoming faulty due to defective material or manufacture within 5 years of the date of purchase, please return it to your supplier in the first year with proof of purchase and it will be replaced free of charge.

For years 2 to 5 or any difficulty in the first year telephone the helpline on 020 8450 0515.



HELPLINE
020-8450-0515



For a product brochure please contact:

Timeguard Ltd.

Victory Park, 400 Edgware Road,
London NW2 6ND

020-8452-1112

or email csc@timeguard.com

**RECEIVER
CONTROLLER**
Cat No. TLRX05



**INSTALLATION & OPERATING
INSTRUCTIONS**

Introduction

The TLRX05 In Line Receiver is part of the Timeguard range of products which communicate by radio frequency (r.f.) signals.

This enables substantial amounts of wiring to be eliminated which is particularly useful in long runs and coverage of outbuildings.

It is an In Line Receiver which receives r.f. signals from transmitters it has been programmed to recognise and turns connected lighting on.

In the following instructions products with catalogue numbers including Tx (ones that send information about PIR detection) are referred to as Tx units and products with catalogue numbers including Rx (ones that receive information about PIR detection) are referred to as Rx units.

A

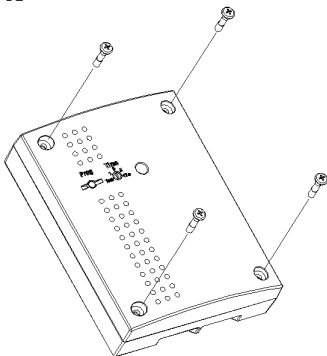

C

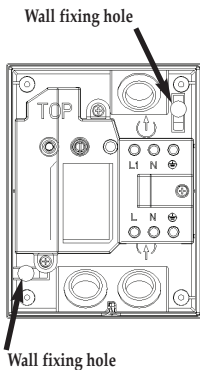

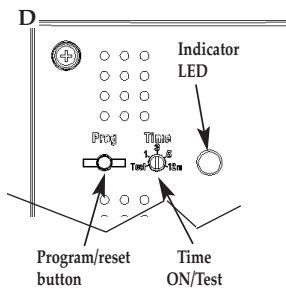
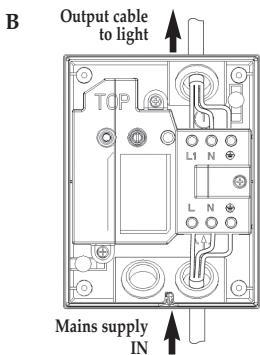

Parts included

- In Line receiver unit.
- Instruction manual. Please keep safe for future reference.
- Accessory Pack.

Tools and parts needed

- Electric/hand-held drill & bits.
- Terminal or Electricians screwdriver.
- Large slotted/philips screwdriver.
- Wire cutters.

Selecting a location

This unit can be used to control lighting indoors or outdoors. The unit is designed for use with fixed wiring only. Ensure that the incoming and outgoing cables are protected from water ingress by use of silicon sealant around the cable inlets.

Do not attempt to install during wet weather, or if you are suffering from nausea or dizzy spells or on medication with similar side effects.

If in any doubt, consult a qualified electrician.

The In Line Receiver must be within transmission range of your chosen transmitter. The In Line receiver can be placed at any convenient break point of the wiring connected to the luminaire it is intended to control. We suggest that the Transmitter is placed in its optimum position to give the coverage and detection required, then the In Line receiver is placed at a point where it can receive the Transmitter's signal. To ensure that the Receiver is receiving the transmission signal. This will be less than 100m away if walls or chain link fences come between the Tx and Rx units - if there is any doubt about whether communication will take place make temporary installations before programming.

Installation

IMPORTANT

Switch off the electricity at the fuse box by removing the relevant fuse or switching off the circuit breaker before proceeding with the installation.

Remove the front cover of the TLRX05 by removing the 4 x cover fixing screws as (Fig A).

Mark position of the fixing holes. (Fig B).

Drill the holes. Insert the wall plugs into the holes.

PASS THE CABLE THROUGH THE INCOMING AND OUTGOING CABLE GROMMETS BEFORE FIXING THE UNIT TO THE WALL.

Allow approximately 100mm of cable to pass through the grommet. (A template for this wire length is provided on page 8 of this manual). Fit grommet into its location hole ensuring a good seal.

Fix the unit to the wall. Take care not to overtighten the screws to prevent damage to the mounting plate. If using a power screwdriver, use the lowest torque setting.

Connection

Connect the incoming mains cable through one of the lower grommets and into the terminal block as follows (see connection diagram):

NEUTRAL (Blue) N

EARTH (Green/Yellow) 

LIVE (Brown) L

Ensure the connectors are secure.

Connect the cable connected to the switched luminaire through the upper grommet to the terminal block as follows (see connection diagram Fig B):

NEUTRAL (Blue) N

EARTH (Green/Yellow) 

LIVE (Brown) L1

Ensure the connectors are secure.

Replace front cover and fully tighten the 4 fixing screws as (Fig A).

Programming

Each Rx unit needs to learn the codes involved in the messages from all the Tx units which are required to control it (up to 20).

① Turn OFF/remove batteries from any Tx unit which is not required to control this RX unit. Turn off any other Rx units. If it is convenient more than one Rx unit can learn the code of a Tx unit simultaneously in which case leave these Rx units switched ON.*

② The Rx unit needs to be set in programme mode. This will happen automatically up to 4 seconds after the Rx unit is first powered up. It can also be set by pressing the Programme/ Reset button for 1 to 2 seconds (pressing for 5 seconds or longer will erase all programming within the Rx unit). In either case the Time On/Test control must be set to Test which will give a 5 minute period of programme mode. The lights under control of the Rx unit will turn on at the start of this period indicating it is in progress.

③ Go to the Tx unit** to be introduced to the Rx unit and move across the face of its PIR lens within detection range causing it to detect (indicated by the lights under control turning ON for most Tx units and by a flash from the red LED on the TLTXDCB).

④ Return to the Rx unit and check that it has turned the lamps under its control off (indicating correct code learning).
*Any other Rx units left connected should now be checked in the same way.

Press the Programme/Reset button for 1 to 2 seconds*** if the Rx unit is required to learn the code of another Tx unit.

*Any other Rx units required to learn the code of this new Tx unit should be left connected.

** If introducing the TLTXK2 hand held transmitter press the "1" button on this unit to activate the TLRX05.

***If the button is pressed for 5 seconds or more then all the codes that have been learnt will be erased.

5. If the lights did not go OFF in step 4 page 5 the Rx is not picking up a signal. Check the radio signal path between the Sensor and Receiver for any metal obstructions (support beams, chain link fences etc). These can block radio signals and interfere with signal transmission. A way to check path if using the Battery Powered Detector TLXDxCB is to set the Rx On time dial to test, remove the sensor from its location and walk the sensor around the Rx. As you walk, wave your hand in front of the sensor Tx. Note when the it turns the Rx light OFF, and re mount in that area.

Settings

After Programming, set the ON TIME dial.

To set how long the lamp will remain ON after the TLRX05 hs received a signal from a Tx unit, set the ON TIME dial on the RX to 1, 3 , 5 or 12 minutes. See fig D.

Manual override

The lamp can be turned on and off independently of any transmission signal by switching the unit off/on once in less than two seconds To return to Auto Mode repeat this switching action.

Erasing all codes

Tx unit codes can be erased for reprogramming. To erase codes, while the TLRX05 is powered, press and hold the PROGRAM button for more than 5 seconds. The light will turn on, go out and then turn on again. This will clear the unit of all programmed codes and place it back into the AUTO PROGRAMMING Mode.

Now return to the Programming Section.

Troubleshooting guide

Problem	Solution
<ul style="list-style-type: none">• Light will not come on when motion is sensed.	<ol style="list-style-type: none">1. The installation switch is turned off.2. Light bulb is loose or burned out3. Sensor is positioned too far from receiver. Move Tx closer
<ul style="list-style-type: none">• Light Comes on in Daylight.	<ol style="list-style-type: none">1. Tx unit is installed in a dark location.2. Receiver is in Manual Override Mode. Flip Transmitter wall switch Off then On twice to place back into Auto Mode
<ul style="list-style-type: none">• Light Stays on.	Receiver is in Manual Override. Flip wall switch Off then ON twice to place back into Auto Mode.
<ul style="list-style-type: none">• Light Flashes on and off twice when activated.	This is the Low battery signal. replace batteries in the Transmitter.
<ul style="list-style-type: none">• Light comes on irregularly when motion is sensed.	<ol style="list-style-type: none">2. The Tx unit is positioned too far from receiver. Move Tx closer.

Technical specifications

Power Supply:	230 V AC ~ 50Hz
Maximum Switchable Load:	2000W (e.g. 4 x 500W Tungsten Halogen)
Time On Adjustment:	1, 3, 5 and 12 minutes
Environmental Protection:	IP44 (suitable for outdoor use)
Transmission Range:	Up to 100m (varies with surrounding structures)
Conforms to Directives:	73/23/EEC and 89/336/EEC

Incoming Wire Template

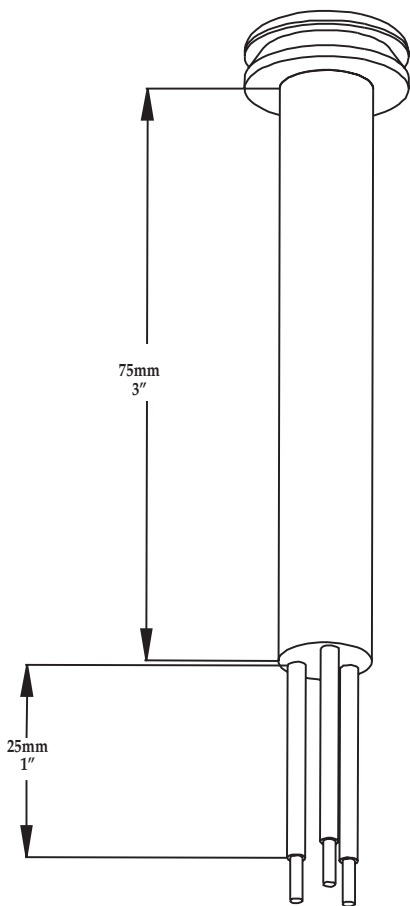

Use this template to estimate incoming cable length

5 Year Guarantee

In the unlikely event of this product becoming faulty due to defective material or manufacture within 5 years of the date of purchase, please return it to your supplier in the first year with proof of purchase and it will be replaced free of charge.

For years 2 to 5 or any difficulty in the first year telephone the helpline on 020 8450 0515.



HELPLINE
020-8450-0515



For a product brochure please contact:

Timeguard Ltd.
Victory Park, 400 Edgware Road,
London NW2 6ND
020-8452-1112
or email csc@timeguard.com