

VD120TH-VFAL12

DNR Dome Camera

Product Information

New state-of-the-art implementation of DSP technologies are optimized for the demands of 24/7 professional applications. Built-in Dynamic Noise Reduction offers a great improvements to reduce the file size of DVR recording and high quality of image capturing capability. High performance CCD sensor is used with a new DSP chip to improve the resolution up to 530TVL at daytime and 570TVL at Nighttime. Sense-up is another specialty applied for this model to increase the sensitivity up to 0.3lux/F1.2 with Super HAD CCD sensor. The image gives a perfect color in daytime and automatically changes into noiseless B/W image at night time making the picture quality the best and ever clear for low light circumstances. The unit supports user-friendly on-screen display (OSD) with an improved function controls and ease of operation. Camera identification can be set up to assign a name of camera with 15 alphanumeric characters. 3-Axis structure combined with tilt down 90 degree surveillance provides a useful way of installation mountable to any place.

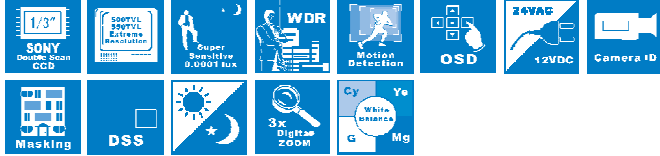

Key Features

- 1/3" DSP Color CCD sensor (Sony Super HAD)
- Dynamic Noise Reduction Technology
- Extremely high resolution 530TVL/daytime & 570TVL/nighttime
- Auto IRIS (DC iris lens)
- Day & Night mode convertible by OSD
- Excellent sensitivity
- SENS-UP (0.3Lux~ 0.0002 Lux at 128x~2x Fields)
- Easy to use OSD (On Screen Display) menu
- 12VDC/24VAC Line Lock

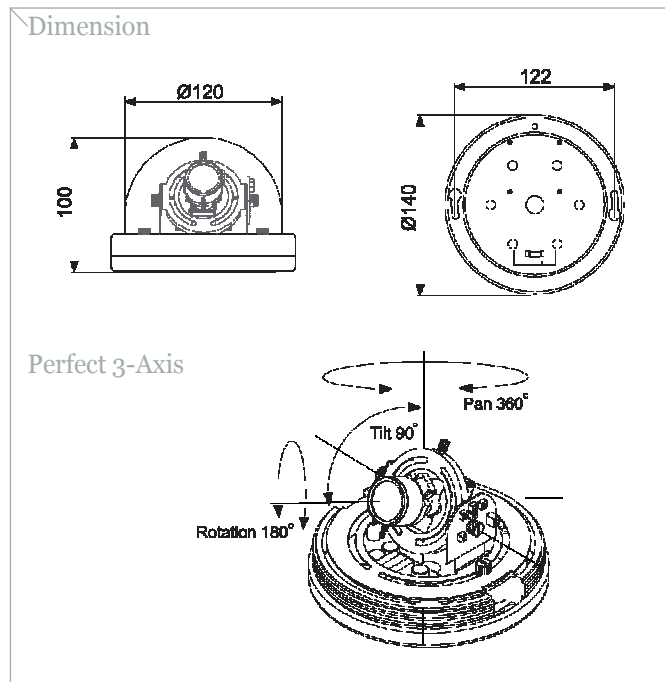

MODEL	VD120TH-VFAL12
Power Source	DC12V/AC24V Dual Power
Operating Current	200mA(12V)/110mA(24V)
Sensor	1/3" Super HAD CCD
Total Pixels	NTSC : 811(H)X508(V) PAL : 795(H)X596(V)
Effective Pixels	NTSC : 768(H)X494(V) PAL : 752(H)X582(V)
Scanning System	NTSC 525 Lines PAL 625 Lines 2:1 Interlaced
Synchronizing System	Internal/Line Lock
Frequency	NTSC - Horizontal : 15.743KHz Vertical : 59.94Hz PAL - Horizontal : 15.625KHz Vertical : 50Hz
Resolution	530TVL(Day)/570TVL(Night)
S/N Ratio	50dB(AGC Off)
Video Out	CVBS : 1.0Vp-p Composite. 75 Ohms
Min. Illumination	0.3Lux/F1.2, 0.0002Lux(Sens-up x 128 Max.)
Electronic	Auto/Manual
Shutter Speed	NTSC : 1/60 ~ 1/100,000 sec PAL : 1/60 ~ 1/100,000 sec
OSD	Built-in
White Balance	ATW/AWC/Manual selectable (1,800°K - 10,500°K)
BLC	Low, Middle, High, Off selectable
AGC	Low, Middle, High, Off selectable
DNR	Low, Middle, High, Off selectable
Color	Auto(Day & Night)/On(Color only)
SYNC	Internal/Lock Lock selectable
Privacy	On/Off(4 Zone)
Mirror	On/Off
Sharpness	On/Off(Level Adjustable)
Lens	3.3-12mm VF Auto DC Iris Lens
MTBF	80,000 hours
Operating Temperature	14° F~122° F (-10° C ~ +50° C)
Humidity	Within 90% RH
Cable	4 Feet DIY cable with BNC-Fe for Video & DC-Ma or 2pin terminal for Power
Dimension	140(Dia.) x 100(V)
Weight(Approx.)	250g