

WCO-628 Datasheet Trade

Wi-Safe Digital Carbon Monoxide Poisonous Gas Alarm

GN0243/R1

Product Image



Product Dimensions (mm)

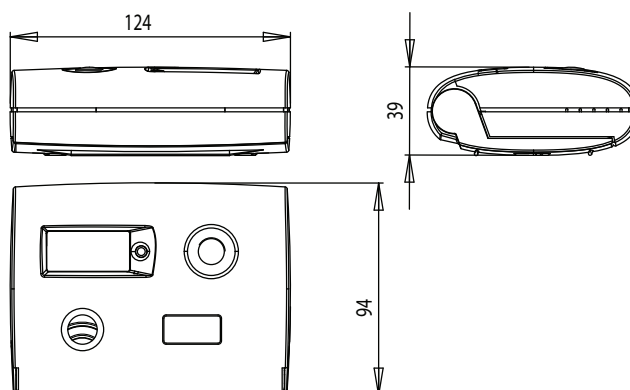

Model Number	WCO-628
Retail Description	N/A
Retail EAN Number	N/A
Retail Packaging Format	N/A
Retail Packaging Dimensions WxHxD	N/A
Retail Packaging Weight	N/A
Retail SRP Quantity	N/A
Trade Description	Wi-Safe Digital Carbon Monoxide Poisonous Gas Alarm
Trade EAN Number	0816317000639
Trade Packaging Format	Cardboard Box and Recyclable PET Tray and Window
Trade Packaging Dimensions WxHxD	165mm x 133mm x 48mm
Trade Packaging Weight	334g (including alarm, manual and batteries)
Trade Outer Box Quantity	5
Warranty	6 Years
Technology	Sensor: Electrochemical cell Communication: Wi-Safe Wireless
Operation AC/DC	DC
Battery Type	Alkaline (with optional lithium)
Product Weight	229g (including battery)

Alert Type	Loud 85dB alarm at 1 metre + red flashing LED Digital display shows levels of CO between 10 and 999ppm (parts per million)
Operating Temperature	-10°C to +40°C
Operating Humidity	30% to 90% RH non-condensing
Installation Positions	Wall / Shelf
Approvals	Independently tested to conform to BS EN 50291:2001 ETSI EN 301 489-3 v1.4.1 (2002-08) ETSI EN 301 489-1 v1.6.1 (2005-09) EN 300 220-1 v1.3.1 (2000) EN 300 220-3 v1.1.1 (2000)
Wi-Safe RF	433.920 MHz 24-bit encryption
WCO-628 connects to	WBS-616, WVP-626, WFS-627, WFSVP-629

Health & Safety Information

Storage Temperature	-20°C to +60°C
Storage Humidity	30% to 90% RH non-condensing



Independently tested to conform to BS EN 50291:2001

