

Wi-Safe Strobe and Vibrating Alert System

Product Image

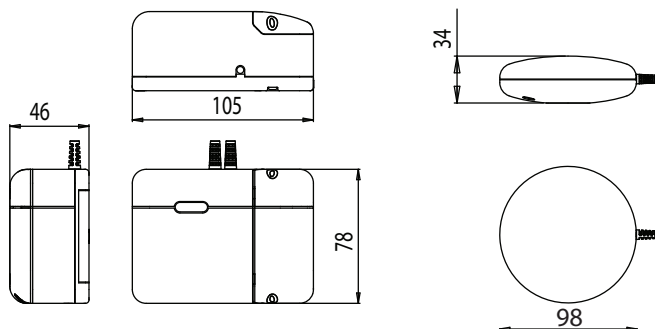

Product Dimensions (mm)



Model Number	WFSVP-629
Retail Description	N/A
Retail EAN Number	N/A
Retail Packaging Format	N/A
Retail Packaging Dimensions WxHxD	N/A
Retail Packaging Weight	N/A
Retail Outer Box Quantity	N/A
Trade Description	Wi-Safe Strobe and Vibrating Alert System
Trade EAN Number	0816317000875
Trade Packaging Format	Recycled Cardboard Box
Trade Packaging Dimensions WxHxD	157mm x 95mm x 112mm
Trade Packaging Weight	522g (Including Wi-Safe Flashing Strobe Alert System, AC/DC mains adaptor, manual, batteries and fixings)
Trade Outer Box Quantity	12
Warranty	10 Years
Technology	Communication: Wi-Safe Wireless
Operation AC/DC	AC mains with DC rechargeable battery
Battery Type	Rechargeable Ni-Mh battery only
Product Weight	430g (including battery)
Alert Type	Xenon bulb flashing strobe Individual vibration and flashing LED patterns for smoke and carbon monoxide alert

Operating Temperature	-5°C to +40°C
Operating Humidity	Up to 90% RH non-condensing
Installation Positions	Vibrating Pad: Under pillow, mattress or seating cushion Flashing Strobe: Where the strobe can be seen from anywhere in the room
Approvals	Independently tested to conform to the following european standards: EN 301 489-01 v1.6.1 (2005-09) EN 301 489-3 v1.4.1 (2002-08) EN 300 220-3 v1.1.1 (2000) BS EN 60065 (2002) BS EN 60950 (2006) BS EN 50130-4 (1995) BS EN 55022 (2006)
Wi-Safe RF	433.920 MHz 24-bit encryption
WFSVP-629 receives signals from	WSI-601, WSO-601, WSO-610, WLSO-610, WCO-628
Wi-Safe Product Memory	20 alarms

Health & Safety Information

Storage Temperature	-20°C to +60°C
Storage Humidity	Up to 93% RH non-condensing

