

## WSO-610 Datasheet

# Wi-Safe 10 Year Optical Smoke Alarm



## Product Image

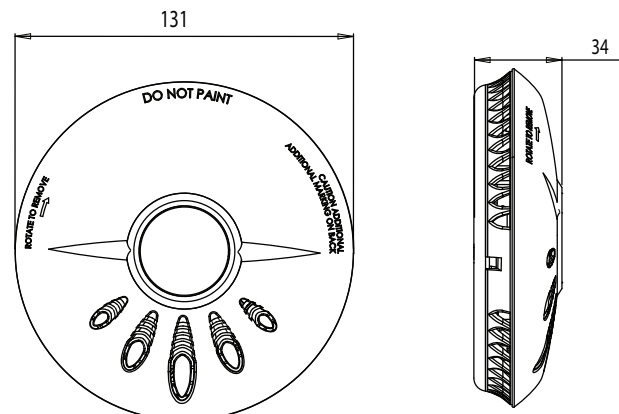

## Product Dimensions (mm)



<b>Model Number</b>	WSO-610
<b>Retail Description</b>	N/A
<b>Retail EAN Number</b>	N/A
<b>Retail Packaging Format</b>	N/A
<b>Retail Packaging Dimensions WxHxD</b>	N/A
<b>Retail Packaging Weight</b>	N/A
<b>Retail SRP Quantity</b>	N/A
<b>Trade Description</b>	Wi-Safe 10 Year Optical Smoke Alarm
<b>Trade EAN Number</b>	N/A
<b>Trade Packaging Format</b>	Recycled Cardboard Box
<b>Trade Packaging Dimensions WxHxD</b>	136mm x 136mm x 43mm
<b>Trade Packaging Weight</b>	245g (including alarm, manual and fixings)
<b>Trade Outer Box Quantity</b>	20
<b>Warranty</b>	10 years
<b>Technology</b>	Sensor: Optical (Photoelectric) Communication: Wi-Safe Advanced Wirefree Technology
<b>Operation AC/DC</b>	DC
<b>Battery Type</b>	Non-removable integrated lithium power pack - 10 year life in normal operating conditions
<b>Product Weight</b>	197g (including power pack)

<b>Alert Type</b>	Loud 85dB alarm at 3 metres + red flashing LED
<b>Operating Temperature</b>	+4°C to +38°C
<b>Operating Humidity</b>	Up to 90% RH non-condensing
<b>Installation Positions</b>	Ceiling / Wall
<b>Approvals</b>	Independently tested to conform to BS EN 14604:2005 ETSI EN 301 489-1 v1.6.1 (2005-09) ETSI EN 301 489-3 v1.4.1 (2002-08) EN 300 220-3 v1.1.1 (2000) BS EN 60065 (2002) BS EN 60950 (2001) EN 50130-4 (1995) BS EN 61000-6-3 (2001)
<b>Wi-Safe RF</b>	433.920 MHz 24-bit encryption
<b>WSO-610 connects to</b>	WBS-616, WWP-626, WFS-627, WFSVP-629
<b>Health &amp; Safety Information</b>	
<b>Storage Temperature</b>	-20°C to +60°C
<b>Storage Humidity</b>	Up to 93% RH non-condensing
<b>Storage Licensing Requirement</b>	N/A
<b>Isotope Activity</b>	N/A
 Independently tested to conform to BS EN 14604:2005 	

# FireAngel®

**FireAngel Ltd.**  
The Technocentre, Puma Way  
Coventry CV1 2TT UK

**Tel** +44 (0)24 7623 6600  
**Fax** +44 (0)24 7623 6603  
**Web** [www.fireangel.co.uk](http://www.fireangel.co.uk)