



Document No. **NISM/EV-UV/01**  
Date **NOV 2003**

# evolution-advanced

## **EV-UV ANALOGUE ADDRESSABLE ULTRAVIOLET FLAME SENSOR INSTRUCTION MANUAL**



Quality System Certificate No. 041  
Assessed to BS EN ISO 9001:2002



**evolution-advanced**  
**EV-UV ANALOGUE ADDRESSABLE**  
**ULTRAVIOLET FLAME SENSOR**  
**INSTRUCTION MANUAL**

Ref No: **NISM/EV-UV/01**

DATE: **JUNE 2003**

PAGE: **1 of 7**

ISSUE: **01**

# evolution.....

*The new **EV-UV** advanced analogue addressable flame sensor forms part of a brand new range of analogue addressable fire sensors from Nittan (UK) Ltd called **evolution-advanced**.*

*The **EV-UV** together with the **EV-PH, EV-H, EV-P** and **EV-DP** are all elegantly designed, low profile fire sensors which are aesthetically pleasing, thus enabling them to blend unobtrusively into modern working environments.*

*The **evolution** analogue addressable range all feature the very latest technological advancements such as ASIC design, increasing reliability and performance.*

# evolution-advanced.....



**evolution-advanced**  
**EV-UV ANALOGUE ADDRESSABLE**  
**ULTRAVIOLET FLAME SENSOR**  
**INSTRUCTION MANUAL**

Ref No: **NISM/EV-UV/01**

DATE: **JUNE 2003**

PAGE: **2 of 7**

ISSUE: **01**

**CONTENTS:-**

|                   |   |                                   |          |
|-------------------|---|-----------------------------------|----------|
| <b>Section 1</b>  | - | <b>Introduction</b>               | - Page 2 |
| <b>Section 2</b>  | - | <b>Sensor models</b>              | - Page 2 |
| <b>Section 3</b>  | - | <b>Base Models</b>                | - Page 2 |
| <b>Section 4</b>  | - | <b>Location</b>                   | - Page 3 |
| <b>Section 5</b>  | - | <b>Installation</b>               | - Page 3 |
| <b>Section 6</b>  | - | <b>Maintenance &amp; Cleaning</b> | - Page 3 |
| <b>Section 7</b>  | - | <b>Specifications</b>             | - Page 4 |
| <b>Section 8</b>  | - | <b>Environmental Parameters:-</b> | - Page 4 |
|                   |   | - Temperature                     | - Page 4 |
|                   |   | - Humidity                        | - Page 4 |
| <b>Section 9</b>  | - | <b>EMC</b>                        | - Page 4 |
| <b>Section 10</b> | - | <b>Connections</b>                | - Page 4 |
| <b>Section 11</b> | - | <b>Dimensions</b>                 | - Page 5 |
| <b>Section 12</b> | - | <b>Area Coverage</b>              | - Page 5 |
| <b>Section 13</b> | - | <b>Flameproof Housing</b>         | - Page 7 |

**Section 1 - INTRODUCTION**

The EV-UV is an attractively-styled, low profile ultraviolet flame sensor for use with Nittan 'evolution' protocol control panels.

The EV-UV utilises the ultraviolet light detection method.

**EV-UV features:**

\* **Ultraviolet sensor, detecting ultraviolet light emitted by flames**

\* **Low profile, stylish appearance**

\* **Supplied with protective dust cover, (remove during commissioning)**

\* **Low monitoring current**

\* **Remote indicator output**

\* **Non-polarised terminals**

\* **Compatible with STB-4-EV and STB-4SE-EV bases**

**Section 2 - SENSOR MODELS**

The EV-UV ultraviolet flame sensor has two terminals for connection onto the two wire loop. The remaining terminal provides a switched current sink function which operates when the detector goes into alarm condition, suitable for the operation of an auxiliary function such as a remote indicator. Terminal 3 (RIL) is limited to 3mA.

**Section 3 - BASE MODELS**

A variety of bases are available for use with the EV-UV sensor. It is important to use the correct base for each application. The available base models are:

**i) STB-4-EV base:** For standard use with EV-UV series ultraviolet flame sensor.

**ii) STB-4SE-EV base:** Similar to STB-4-EV base, except deeper.



**evolution-advanced**  
**EV-UV ANALOGUE ADDRESSABLE**  
**ULTRAVIOLET FLAME SENSOR**  
**INSTRUCTION MANUAL**

|         |                      |
|---------|----------------------|
| Ref No: | <b>NISM/EV-UV/01</b> |
| DATE:   | <b>JUNE 2003</b>     |
| PAGE:   | <b>3 of 7</b>        |
| ISSUE:  | <b>01</b>            |

**Section 4 - LOCATION**

**Note: Use correct sensitivity position. See Section 12 on page 5 for more details on positioning.**

- i) Determine suitable mounting location according to supervision angle range and effective detection range.*
- ii) Avoid mounting by such angles that two detectors supervise each others protected area unnecessarily.*
- iii) Avoid mounting around openings for ventilation because of dust and dirt contamination.*
- iv) Avoid mounting in such as way as the sensor covers external doors or windows, as ultraviolet light may enter the range of the detector and cause false alarms.*
- v) Avoid mounting in areas such as workshops in case of false alarm from welding etc. If this is unavoidable the source should be shielded with plain glass.*
- vi) In the case of supervising certain obstructions ensure there are no dead areas.*

**Section 5 - INSTALLATION**

*In normal use, the EV-UV sensor will be installed at ceiling level, however it is permissible to mount the sensor at an angle (See Section 12 for details). Pass the field wiring through the cable hole in the centre and from the rear of the base. Offer up and affix the base to the ceiling or conduit fitting with screws via the base mounting holes. Consider visibility of the sensor's integral LED alarm indicator when mounting the base. Connect the field wiring to the base terminals, as detailed on page 6 making sure the wiring does not obstruct fitting of the detector head. Fit the sensor head by inserting it into the base and turning clockwise until the lugs align with the base.*

**Note: The address must be set before the sensor is fitted into place.**

*Keep the plastic dust cover supplied over the sensor until the system is fitted to prevent the quartz window from becoming scratched.*

**NOTE: THE PLASTIC DUST COVER MUST BE REMOVED FROM THE SENSOR IN ORDER FOR THE SENSOR TO FUNCTION CORRECTLY.**

**Section 6 - MAINTENANCE AND CLEANING**

**Maintenance:**

*The EV-UV detector is a high quality product engineered for reliability. If proper preventative maintenance is not carried out, there is a likelihood of malfunction, including false alarms.*

**Servicing:**

*Servicing of the system should be carried out in accordance with the requirements of BS 5839 Part 1, Fire Detection and Alarm Systems for Buildings: Code of Practice for System Design, Installation and Servicing.*

*The maintenance procedures described below should be conducted with the following frequency:*

- One month after installation: Routine Inspection and every 3 months thereafter.*
- Every 6 months: Operational Test.*
- Every 12 months: Functional Test and Clean.*

*All above frequencies of maintenance are dependent on ambient conditions.*

**Routine Inspection**

- i) Ensure the sensor head is secure and undamaged.*
- ii) Ensure the surface of the sensor's outer cover is clean. If there are deposits due to the presence of oil vapour, dust etc, then the sensor should be cleaned in accordance with the cleaning instructions detailed later in this manual. It may be advisable to ensure that such cleaning is conducted regularly in the future.*
- iii) Ensure no equipment which may emit ultraviolet light has been installed in the vicinity of the detector since the last routine inspection. If such equipment has been installed, then you should notify the Fire Safety Officer or other competent authority that its presence may cause false alarms.*

**Operational Test**

*The purpose of the Operational Test is to confirm the sensor's correct operation in response to a smoke condition.*

**Note: When carrying out site testing of Analogue Addressable Evolution detectors, the CIE shall be set to test mode prior to beginning the tests.**

- i) Take any necessary precautions at the control panel to limit the sounding of the alarm sounders/bells and any fire service summoning device.*
- ii) Introduce a naked flame into the range of the sensor by using a lit match or cigarette lighter held 1-10m in front of the detector. Check that the detector gives an alarm condition within 15 seconds. Check the LED indicator on the EV-UV sensor illuminates and any remote indicator LED fitted also illuminates.*



evolution-advanced  
EV-UV ANALOGUE ADDRESSABLE  
ULTRAVIOLET FLAME SENSOR  
INSTRUCTION MANUAL

Ref No: NISM/EV-UV/01

DATE: JUNE 2003

PAGE: 4 of 7

ISSUE: 01

iii) After the sensor has given the alarm condition, reset the sensor from the control panel. It may be necessary to allow a short time to elapse before resetting the detector.

**Functional Tests:**

The functional test checks the detector's operation. These detectors may be returned to our factory for Functional Testing

**Cleaning:**

**Note: The sensor head should NOT be disassembled.**

i) Carefully remove the sensor head from its base.

ii) Use a soft, lint-free cloth, moistened with alcohol for sticky deposits, to clean the plastic casing. Be careful not to wipe abrasive particles, e.g. dust and grit, across the quartz glass window of the detector when cleaning.

iii) If the unit needs further cleaning, or is damaged or corroded, please return the complete sensor to Nittan (UK) Ltd. for service.

**Section 7 - SPECIFICATIONS**

|                                   |   |                                     |
|-----------------------------------|---|-------------------------------------|
| <b>Model Reference:</b>           | - | EV-UV                               |
| <b>Computer Reference:</b>        | - | F16J71005                           |
| <b>Sensing Wavelength:</b>        | - | 185 - 260nm                         |
| <b>Detection Angle:</b>           | - | 100 degrees                         |
| <b>Sensor Type:</b>               |   | UV Tron (Part #: R2868)             |
| <b>Operating Current:</b>         | - | 1mA<br>fire alarm (LED on)<br>5.2mA |
| <b>Standard:</b>                  | - | EN54 Part 10:2001                   |
| <b>Mass:</b>                      | - | 102g (excluding base)               |
| <b>Charging Time:</b>             | - | 20 seconds                          |
| <b>Ambient Temperature Range:</b> | - | -10 °C to +55 °C                    |
| <b>IP Rating:</b>                 | - | 51                                  |

**Section 8 - ENVIRONMENTAL PARAMETERS**

**Temperature Considerations:**

Over the range from -10 °C to +55 °C

**Humidity:**

Relative Humidity of up to 95%, measured at 50 °C, non condensing.

**Section 9 - EMC**

**Installation**

The installation shall be in accordance with the regulations either of the approval body for an approved system, or otherwise, to the national code of practice/ regulations for the installation of the fire alarm system, e.g. BS 5839 part 1.

**Electromagnetic Compatibility (EMC)**

On a site where there is an unusually high level of potential electrical interference, e.g. where heavy currents are being switched or where high levels of R.F. are prevalent, care then must be taken in the type and routing of cables. Particular care should be given to the separation of zone wiring from the cable carrying the interference.

**Section 10 - CONNECTIONS**

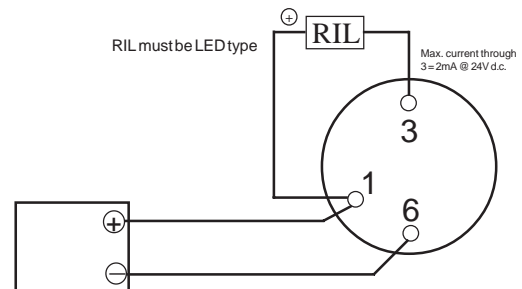

Auxiliary terminal RIL current limited to 2mA.



**evolution-advanced**  
**EV-UV ANALOGUE ADDRESSABLE**  
**ULTRAVIOLET FLAME SENSOR**  
**INSTRUCTION MANUAL**

Ref No: **NISM/EV-UV/01**

DATE: **JUNE 2003**

PAGE: **5 of 7**

ISSUE: **01**

**Section 11 - DIMENSIONS**

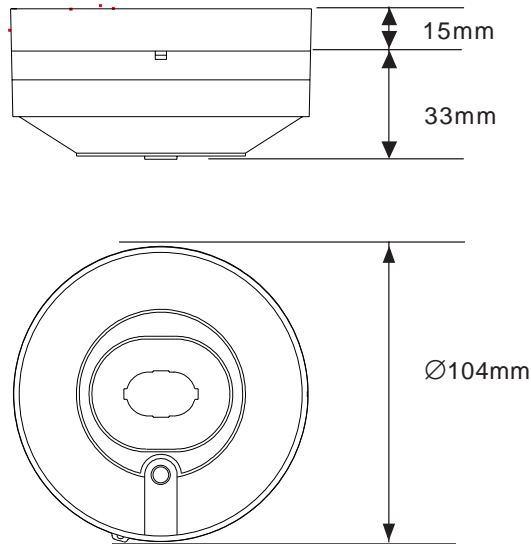

**Section 12 - AREA COVERAGE**

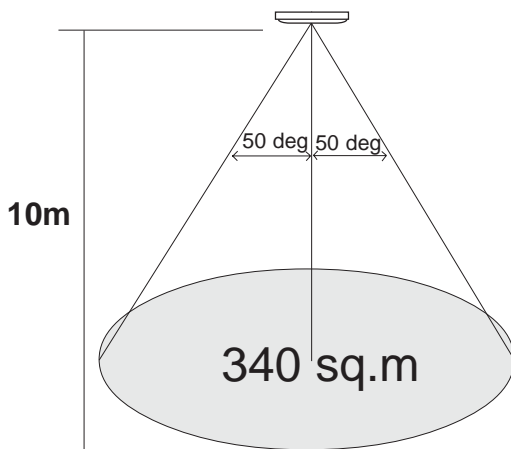

**Fig. 1.**

*Fig. 1. shows the area coverage of an EV-UV detector when mounted at a height of 10 metres on a ceiling. The approximate area coverage is 340 square metres.*

*Fig. 2. shows the area coverage of an EV-UV detector when wall mounted at a height of 10 metres on a ceiling. The approximate area coverage is 570 square metres.*

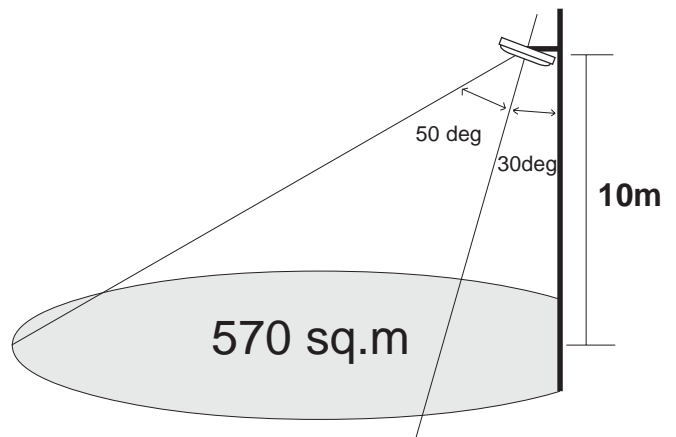

**Fig. 2.**



**evolution-advanced**  
**EV-UV ANALOGUE ADDRESSABLE**  
**ULTRAVIOLET FLAME SENSOR**  
**INSTRUCTION MANUAL**

Ref No: **NISM/EV-UV/01**

DATE: **JUNE 2003**

PAGE: **6 of 7**

ISSUE: **01**

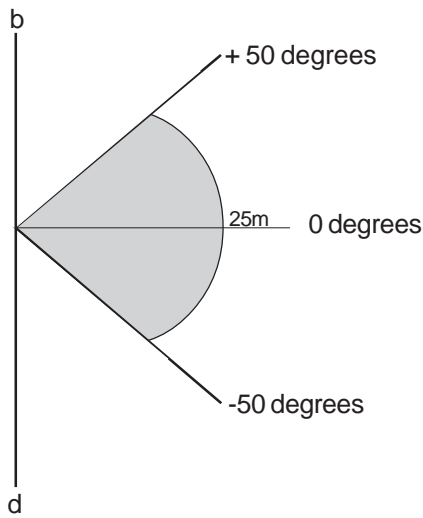
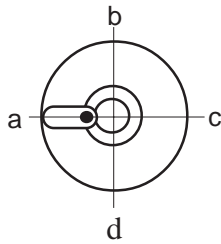

**Fig. 3.**

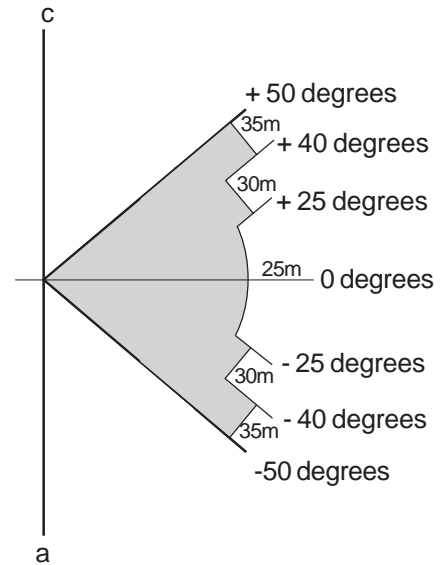
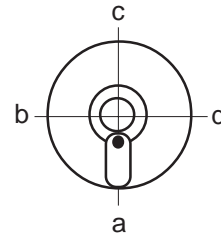

**Fig. 4.**

The EV-UV sensor may be positioned in two ways. Each way determines the distance and area coverage of a single detector.

Fig. 3. shows the EV-UV in the B-D position, and Fig. 4. shows the EV-UV in the C-A position. In both examples, the shaded area indicates the actual detection area achieved for each positioning of the sensor. The examples are based on tests carried out using a fuel fire covering an area of approximately 33 square centimetres. (See Fig. 5.)

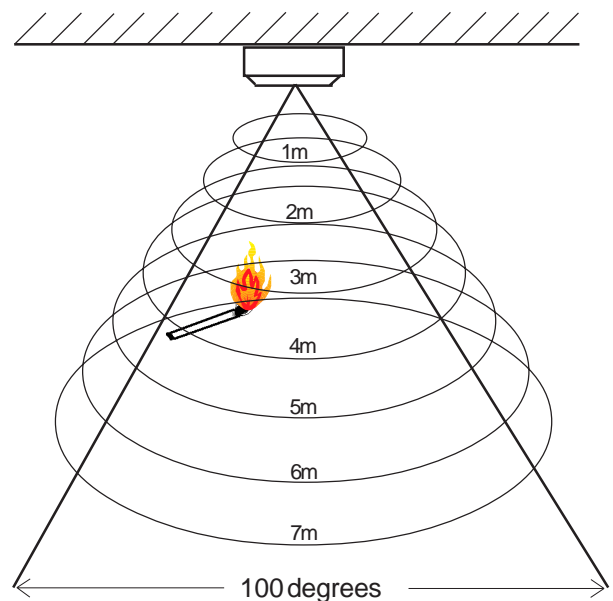
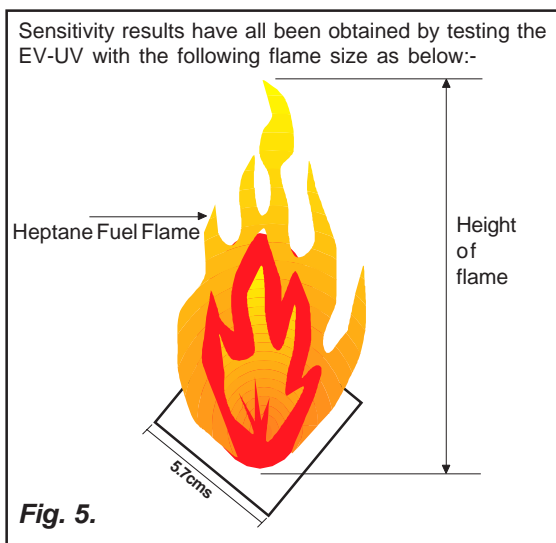

**Fig. 6.**

Fig. 6. demonstrates how the area of coverage of the EV-UV sensor increases the further away from the sensor head you go. The sensor has a maximum detection angle of 100 degrees.



evolution-advanced  
EV-UV ANALOGUE ADDRESSABLE  
ULTRAVIOLET FLAME SENSOR  
INSTRUCTION MANUAL

Ref No: **NISM/EV-UV/01**

DATE: **JUNE 2003**

PAGE: **7 of 7**

ISSUE: **01**

### **Section 13 - FLAMEPROOF HOUSING**

The EV-UV detector may also be used with the NITTAN NFD-FPH Flameproof housing. The NFD-FPH is for use in areas made potentially hazardous by the presence of flammable liquids or vapours (zone 1 or zone 2).

The housing has a threaded cover to enable ease of access for installation and includes internal and external earth terminals suitable for up to 4mm sq. cable. The EV-UV, when installed in the NFD-FPH, requires a special bracket and base inside the housing to enable correct mounting of the flame detector - this is included in the housing.

Fig. 7. (below) is a diagram of the housing.

#### **Flameproof Housing Specifications:**

- Model Reference: - NFD-FPH
- Computer Reference: - F07N\*63542
- Body & Cover - Copper free aluminium (Chromate primed polyester powder coated)
- Locking Screw - Steel zinc plated
- Window - Heat resistant quartz glass
- IP Rating - I.P.66
- Cable Entries - 2 x M20 (1.5mm pitch)
- Weight - 2.3 Kgs

#### **Standards:**

CENELEC  
EN 50014/50018 & NBMC23.001/103  
INIEX  
ATEX Approved to II 2 G D, EExd IIC T6 (85°C)

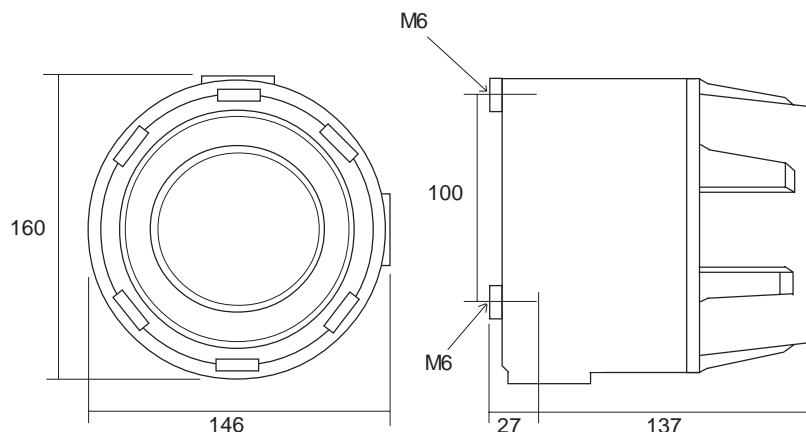

**Fig. 7.**