



Duonet control panel

The Duonet system incorporates a high level of technology, integrated with a 'back to basics' review of the features we take for granted.

The control panel will support 1–2 plug on loop cards, network card available.

The addressable loop utilises the existing technology of the Sita 200 plus devices, with the addition of many additional functions.

Soft Addressing Technology has been enhanced, with the addition of "Safe Initialisation". This allows the engineer to automatically compare the programmed data with the existing loop configuration, which will then prompt to "add/delete/change" any devices which are inconsistent. In this way, addresses may be added into the system as required, even "out" of sequence.

Therefore, the widely acknowledged "best" features of soft addressing have been integrated with the later flexibility of hard addressing.

A full set of programmable inputs and outputs are available at the panel, combining with the improved zonal and point 'Cause & Effect' setup to provide one of the most powerful, configurable and user friendly systems on the market today.

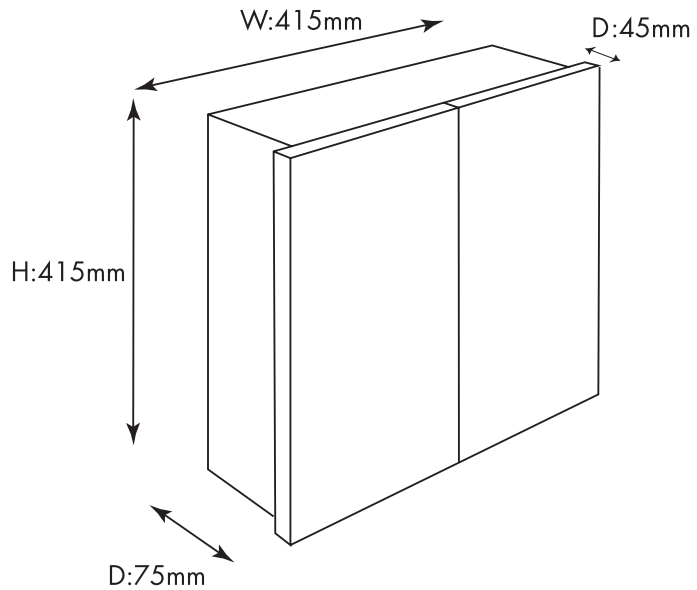

Technical Specification

Compatibility:	Sita 200 plus devices
Construction:	Mild Steel
Operating Temperature:	5°C to 33°C
Voltage Range:	16 to 48 V DC
Mains Voltage:	230V AC +10% -15%
Panel Inputs/Outputs:	2 x programmable relay, SPCO 2 x monitored sounder/relay circuit 2 x monitored input (latching/nonlatching) 2 x network port 1 x PSU bus 1-2 x addressable loop card 1 x USB port for site config upgrade 1 x serial port for panel software upgrade
Loop Voltage:	40v DC
Current Consumption:	Max Loop Current: 500mA Quiescent: 98mA Alarm: 250mA
Battery Requirements:	2 x 12v 7Ah per PSU for 24hr standby
Loop length:	2Km 2core 1.5mm (with screen/earth)
Part Code:	510 0001